



## Tipper Eco series

Operating instructions for all Tipper Eco trailers with a weight class of 750kg.

## Table of Contents

|   |    |
|---|----|
| <i>Foreword</i> .....                                 | 3  |
| <i>Identification</i> .....                           | 3  |
| <i>Confirmation of conformity</i> .....               | 4  |
| <i>Productnames</i> .....                             | 4  |
| <i>Safety and warning instructions</i> .....          | 6  |
| <i>Technical data</i> .....                           | 11 |
| <i>Nameplate / VIN number</i> .....                   | 11 |
| <i>Overview of trailer components</i> .....           | 13 |
| <i>Technical specifications</i> .....                 | 14 |
| <i>Optional equipment and accessories</i> .....       | 15 |
| <i>Electrical installation</i> .....                  | 16 |
| <i>Before setting off</i> .....                       | 17 |
| <i>Coupling</i> .....                                 | 17 |
| <i>Loading and unloading</i> .....                    | 21 |
| <i>Driving the trailer</i> .....                      | 22 |
| <i>Uncoupling</i> .....                               | 23 |
| <i>Ball coupling for unbraked trailers</i> .....      | 24 |
| <i>Auxiliary coupling for unbraked trailers</i> ..... | 26 |
| <i>Wheels and tyres</i> .....                         | 27 |
| <i>Hydraulic lift function</i> .....                  | 29 |
| <i>Cleaning</i> .....                                 | 32 |
| <i>Storage / Parking</i> .....                        | 33 |
| <i>End of life cycle</i> .....                        | 33 |
| <i>Troubleshooting</i> .....                          | 34 |
| <i>Maintenance</i> .....                              | 35 |
| <i>Service intervals and history</i> .....            | 39 |
| <i>Warranty and liability</i> .....                   | 42 |
| <i>Annex I - EG-declaration of conformity</i> .....   | 43 |

## Foreword

Dear Customer,

Congratulations on your purchase of a trailer from BW Trailers.

This Owner's Manual contains all the operating and safety instructions that apply to the trailer. For safety reasons, it is absolutely necessary that you read these instructions carefully in order to guarantee safety for yourself and others before you take the trailer on the public roads.

The maintenance instructions for the trailer are also included in this documentation and must be followed and carried out correctly in order to qualify for the warranty conditions.

If there are any questions after you have read the documentation, you can always contact the manufacturer or dealer for further explanation or information.

The Owner's Manual is part of the trailer and should therefore be kept in a safe place. In case of resale, the Owner's Manual must always accompany the trailer. Extra copies can always be obtained from a dealer or downloaded from our website.

## Identification

This documentation was drawn up in Dutch by BW Trailers BV

|                      |  |
|----------------------|--|
| Version designation: | Operating instructions Tipper Eco series |
| Version date:        | October 2023                             |
| © Copyright:         | BW Trailers BV, Duffel, 2023             |

No part of this documentation may be reproduced in any form without the prior permission of BW Trailers BV.

### **BW trailers BV**

Walemstraat 94 A-B  
2570 Duffel  
Belgium  
Tel: +32 (0)15 34 18 10  
Fax: +32 (0)15 34 18 19  
Mail: [info@bwtrailers.be](mailto:info@bwtrailers.be)  
Web: [www.bwtrailers.be](http://www.bwtrailers.be)

## Confirmation of conformity

The trailer complies with the requirements of the European Directive 2007/46/EC for which the RDW has granted the necessary type approvals.

## Productnames

Tick the type of trailer you have purchased.

| Twin axle trailers - UNBRAKED                        |                          |                                    |                          |
|--|--------------------------|------------------------------------|--------------------------|
| Manually operated                                    | MAM                      |                                    | MAM                      |
|  | 750 kg                   |                                    | 750 kg                   |
| <b>Standard tyre</b>                                 |                          | <b>Low profile tyre (optional)</b> |                          |
| KI-2500x1500-75BTO-H                                 | <input type="checkbox"/> | KI-2500x1500-75BTO-H-LP            | <input type="checkbox"/> |
| KI-3000x1500-75BTO-H                                 | <input type="checkbox"/> | KI-3000x1500-75BTO-H-LP            | <input type="checkbox"/> |
| Manually operated + storage for ramps (optional)     |                          |                                    |                          |
| <b>Standard tyre</b>                                 |                          | <b>Low profile tyre (optional)</b> |                          |
| KI-2500x1500-75BTO-H-VZ                              | <input type="checkbox"/> | KI-2500x1500-75BTO-H-LP-VZ         | <input type="checkbox"/> |
| KI-3000x1500-75BTO-H-VZ                              | <input type="checkbox"/> | KI-3000x1500-75BTO-H-LP-VZ         | <input type="checkbox"/> |
| Electrically operated (optional)                     |                          |                                    |                          |
| <b>Standard tyre</b>                                 |                          | <b>Low profile tyre (optional)</b> |                          |
| KI-2500x1500-75BTO-E                                 | <input type="checkbox"/> | KI-2500x1500-75BTO-E-LP            | <input type="checkbox"/> |
| KI-3000x1500-75BTO-E                                 | <input type="checkbox"/> | KI-3000x1500-75BTO-E-LP            | <input type="checkbox"/> |
| Electrically operated + storage for ramps (optional) |                          |                                    |                          |
| <b>Standard tyre</b>                                 |                          | <b>Low profile tyre (optional)</b> |                          |
| KI-2500x1500-75BTO-E-VZ                              | <input type="checkbox"/> | KI-2500x1500-75BTO-E-LP-VZ         | <input type="checkbox"/> |
| KI-3000x1500-75BTO-E-VZ                              | <input type="checkbox"/> | KI-3000x1500-75BTO-E-LP-VZ         | <input type="checkbox"/> |

| <b>Twin axle trailers - optionally BRAKED</b>               |                          |                                    |                          |
|---|--------------------------|------------------------------------|--------------------------|
| <b>Manually operated</b>                                    |                          | <b>MAM</b>                         | <b>MAM</b>               |
|   |                          | <b>750 kg</b>                      | <b>750 kg</b>            |
| <b>Standard tyre</b>  |                          | <b>Low profile tyre (optional)</b> |                          |
| KI-2500x1500-75BTG-H  | <input type="checkbox"/> | KI-2500x1500-75BTG-H-LP            | <input type="checkbox"/> |
| KI-3000x1500-75BTG-H  | <input type="checkbox"/> | KI-3000x1500-75BTG-H-LP            | <input type="checkbox"/> |
| <b>Manually operated + storage for ramps (optional)</b>     |                          |                                    |                          |
| <b>Standard tyre</b>  |                          | <b>Low profile tyre (optional)</b> |                          |
| KI-2500x1500-75BTG-H-VZ                                     | <input type="checkbox"/> | KI-2500x1500-75BTG-H-LP-VZ         | <input type="checkbox"/> |
| KI-3000x1500-75BTG-H-VZ                                     | <input type="checkbox"/> | KI-3000x1500-75BTG-H-LP-VZ         | <input type="checkbox"/> |
| <b>Electrically operated (optional)</b>                     |                          |                                    |                          |
| <b>Standard tyre</b>  |                          | <b>Low profile tyre (optional)</b> |                          |
| KI-2500x1500-75BTG-E  | <input type="checkbox"/> | KI-2500x1500-75BTG-E-LP            | <input type="checkbox"/> |
| KI-3000x1500-75BTG-E  | <input type="checkbox"/> | KI-3000x1500-75BTG-E-LP            | <input type="checkbox"/> |
| <b>Electrically operated + storage for ramps (optional)</b> |                          |                                    |                          |
| <b>Standard tyre</b>  |                          | <b>Low profile tyre (optional)</b> |                          |
| KI-2500x1500-75BTG-E-VZ                                     | <input type="checkbox"/> | KI-2500x1500-75BTG-E-LP-VZ         | <input type="checkbox"/> |
| KI-3000x1500-75BTG-E-VZ                                     | <input type="checkbox"/> | KI-3000x1500-75BTG-E-LP-VZ         | <input type="checkbox"/> |

## Safety and warning instructions

In order to recognise certain information in this manual more quickly and easily, text and images are indicated with certain symbols, signal words and highlighted text.

### Hazard warnings



This instruction indicates an imminently hazardous situation which, if not avoided, may result in death or serious injury.

Here you can read what the hazard is, what consequences it can have for you and what you need to do to avoid it.  
Observe special precaution.



This instruction indicates a potentially hazardous situation which, if not avoided, may result in death or serious injury.

Here you can read what the hazard is, what consequences it can have for you and what you need to do to avoid it.  
Observe special precaution.



This instruction indicates a potentially hazardous situation which, if not avoided, may result in minor or moderate bodily injury or damage to property.

Here you can read what the hazard is, what consequences it can have for you and what you need to do to avoid it.  
Observe special precaution.



This instruction indicates possible damage to property if the hazard is not avoided.

Here you can read what the hazard is, what consequences it can have for you and what you need to do to avoid it.  
Observe special precaution.

## Hazard symbols indicating particular sources of danger



**Warning of dangerous place!**  
Be careful - several causes can lead to dangers for humans.



**Risk of bruising!**  
People's limbs such as hands / fingers / feet can be bruised.



**Risk of bruising / knocks / of being hit!**  
Persons can be bruised, knocked, hit or generally injured.



**Risk of chemical burns!**  
People can get burns through contact with toxic substances.



**Risk of burns!**  
People can burn themselves on hot surfaces



**Danger when handling batteries!**  
Persons may be injured by leaking battery acid or short circuits



**Risk of electric shock, dangerous voltage!**  
Dangerous voltage can be fatal.



**Risk of environmental pollution!**  
The environment can be polluted when hazardous substances are used incorrectly.

## Mandatory signs



**Important instruction - observe!**  
Indicates important information that must be observed and complied with for safe operation.



**Read the Owner's Manual!**  
It is important to read the Owner's Manual before performing the activity.

## Personal protective equipment



**Safety shoes, sturdy footwear!**



**High visibility clothing, safety vest!**



**Protective gloves!**



**Protective mask, respiratory protection!**



**Apply hand protection!**  
Apply hand protection on your hands before / after the activity.



**Wash hands!**  
Wash your hands thoroughly after the activity has been carried out

## Prohibition Signs



Unauthorised access is prohibited! Keep people at a distance!  
Keep people away from the danger zone.



Do not spray with water!  
Prevent water jets from being sprayed directly onto vulnerable parts of your trailer.



Entry area / zone prohibited!  
Never enter the danger zone / hazardous area during work.

## Other important pictograms



Proper disposal of waste oil!  
Dispose of the waste oil properly.  
Do not dispose of waste in the environment!



Proper disposal of old tyres!  
Dispose of used tyres properly.  
Do not dispose of waste in the environment!



Problematic waste!  
Dispose of the parts properly.  
Do not dispose of any waste in the environment or in household waste!!

## Warnings on the trailer

|  |   |
|--|---|
|  | <p>Als de trailer in stilstand wordt geladen of gelost kan het voorkomen dat de zichtbaarheid van de verlichting en markering niet voldoen aan de wettelijke voorschriften. Plaats een gevarendriehoek om andere weggebruikers te waarschuwen!</p>  |
|  | <p>If the trailer is loaded or unloaded in a stationary state, the visibility of the lighting and marking may not comply with the statutory regulations. Place a warning triangle to warn other road users!</p>                                     |
|  | <p>Si la remorque est chargée ou déchargée à l'arrêt, il peut arriver que la visibilité de l'éclairage et du marquage n'est pas conforme aux exigences légales. Placez un triangle d'avertissement pour avertir les autres usagers de la route!</p> |

|  |   |  |
|--|---|--|
|  | <p><b>VEILIGHEIDSVORSCHRIFTEN KIEPENDE TRAILERS</b></p> <ul style="list-style-type: none"> <li>- Alleen aangekoppeld kiepen</li> <li>- Aanhangswaagen niet laden met aangerokken handrem</li> <li>- Hou alle gevarenzones vrij!</li> <li>- Ontgrendel de nodige zijborden alvorens te kiepen.</li> <li>- Gekepte laadvloer onderhouden bij opeithoud</li> <li>- Schakel de stroomtoevoer uit alvorens te rijden</li> </ul> <p><b>SAFETY REGULATIONS FOR TIPPING TRAILERS</b></p> <ul style="list-style-type: none"> <li>- Tilt only coupled</li> <li>- Do not operate the trailer with the parking brake applied</li> <li>- Keep all danger zones clear</li> <li>- Unlock the necessary side boards before tipping.</li> <li>- Support the buckled loading floor during delays</li> <li>- Switch off the power supply before driving</li> </ul> <p><b>RÈGLES DE SÉCURITÉ POUR LES BENNES</b></p> <ul style="list-style-type: none"> <li>- Basculer uniquement couplée</li> <li>- Ne faites pas fonctionner la remorque avec le frein de stationnement serré</li> <li>- Gardez toutes les zones de danger dégagées</li> <li>- Déverrouillez les panneaux latéraux nécessaires avant de basculer.</li> <li>- Soudenez le plancher de chargement basculé pendant un court laps de temps.</li> <li>- Couper l'alimentation avant de conduire</li> </ul> | <p>Deze trailer werd geproduceerd in overeenstemming met de Machinerichtlijn 2006/42/EG en toevoegsels.</p> <p>This trailer was produced in accordance with the Machinery Directive 2006/42/EC and additves.</p> <p>Cette remorque a été produite conformément à la Directive Machines 2006/42/CE et ses additifs.</p> <p style="font-size: 2em; text-align: center;">CE</p> <p>Model: BW Trailers kipper / tipper / benne<br/>Type: HJ<br/>Voertuigidentificatienummer typeplaat<br/>Vehicle identification number: See type plate<br/>Numéro d'identification du véhicule: plaque signalétique<br/>Bouwjaar / Year of construction / Année de construction: 2018</p> |
|  | <p>BW Trailers BVBA - Walemstraat 94 A-B - 2570 Duffel</p>  | <p>Lees aandachtig de volledige gebruiksaanwijzing en veiligheidsvoorschriften alvorens de trailer in gebruik te nemen.<br/>Carefully read the complete operating instructions and safety instructions before using the trailer.<br/>Lisez attentivement le mode d'emploi complet et les règles de sécurité avant d'utiliser la remorque.</p>  |



## General safety instructions



The owner / operator must have read and understood the Owner's Manual of the trailer thoroughly and completely. Ignoring the safety instructions and not following the steps during operations can lead to accidents involving personal injury. Improper operation can cause serious injury to yourself.

In addition, as a road user, you are obliged to comply with all national and international regulations for driving a vehicle with a trailer.



You must also comply with your duties as the owner of a commercial vehicle. This means regular maintenance, care and the periodic presentation of the trailer for a technical general inspection.



### Ignoring safety instructions / warnings

Ignoring the safety instructions / warnings and not following the steps can lead to accidents involving personal injury. Improper operation can cause serious injury to yourself and others.

## Intended use

The trailer is intended for transporting general goods.

The bucket of a tipper can tip backwards or backwards + sideways using a manually or (optionally) electrically controlled hydraulic tipping system.



The trailer may only be operated by an adult, properly trained, in good physical condition.

## Foreseeable misuse

The trailer is not suitable for:

- Transport of people or animals.
- Unloading of general cargo with the tipping system.
- The use as lifting device for both people and goods.
- Transporting hot materials.
- Carriage of hazardous chemicals subject to authorisation.
- Speeding in adverse weather conditions and / or poor driving surface.
- Use in a damaged condition which can lead to road traffic hazards and personal injury.



As the manufacturer, we accept no liability for personal injury or damage to property caused by foreseeable misuse.



### Children playing near your trailer!

Trailers are no toys! Children cannot properly assess the dangers of a trailer and can injure themselves while playing with the trailer.

Do not let children play near your trailer unsupervised.  
Keep children at a safe distance when manoeuvring your trailer.

The trailers are classified by type and may not be modified according to their permitted equipment!

Changes to the trailer, such as the use of an axle, another make of ball coupling or overrun brake (optional) or non-registered wheels / tyres will lead to loss of approval!

## Technical data

The technical data of your trailer can be found on:

- The accompanying certificate of conformity
- The nameplate
- Type designation in the brochures and sales information on our website [www.bwtrailers.be](http://www.bwtrailers.be)



The loss of the EC certificate of conformity must be reported to the police. A duplicate of these documents can be requested from the manufacturer with official proof of loss.

## Nameplate / VIN number

Each trailer is provided with a nameplate that is permanently attached to the front of the trailer. It provides information about the origin, type and maximum weights of the trailer.

The unique 17-digit VIN number is also shown on the plate but is also engraved on the lower part of the chassis.

See the illustration below for the position of the nameplate and VIN number.

### Position of the nameplate and VIN number

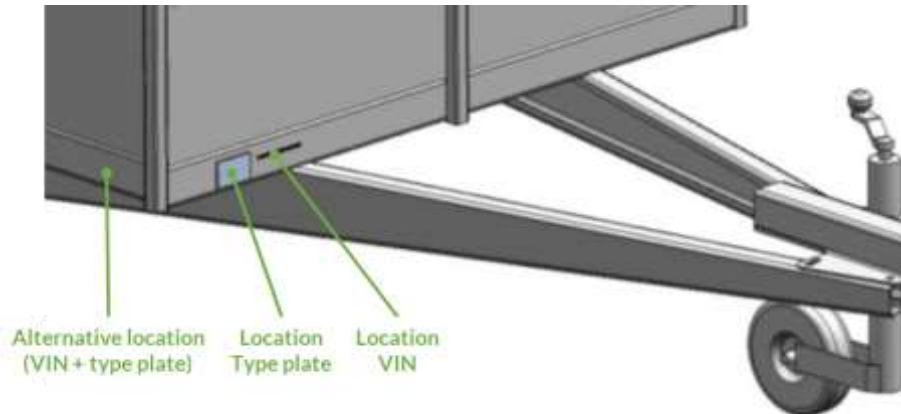

## Example of type plate

|                        |            |    |  |
|------------------------|------------|----|--|
| <b>BW TRAILERS BV</b>  |            |    | ← Manufacturer name                            |
| <b>e4*2007/46*0568</b> |            |    | ← EEC Type-approval number                     |
|                        |            |    | ← 17-digit VIN (vehicle identification number) |
|                        | <b>750</b> | kg | ← Max. authorised mass                         |
| 0-                     | <b>75</b>  | kg | ← Max. drawbar load                            |
| 1-                     | <b>750</b> | kg | ← Max. permissible weight axle 1               |
| 2-                     | <b>750</b> | kg | ← Max. permissible weight axle 2               |
| 3-                     | <b>-</b>   | kg |  |
| <b>Type: O1T</b>       |            |    |  |

↑ Category ECC-type approval



When contacting the manufacturer, you should always have the unique 17-digit VIN number to hand. On the basis of this number, the manufacturer can identify the trailer and request all linked specifications.

## Overview of trailer components



1. Bucket
2. Chassis
3. V-drawbar
4. Coupling
5. Jockey wheel
6. Hydraulic group (operated manually)
7. Tipping cylinder
8. Power plug + holder
9. Breakaway cable (braked models)
10. Ladder carrier
11. Overrun brake (optional)
12. Floor support
13. White wide-beam
14. Spare wheel (optional)
15. Rear light left
16. Rear light right
17. Amber reflector
18. Flap hinge
19. Tension lock
20. Corner post
21. Wheel + tyre
22. Axle



## Technical specifications

|                               | KI-2500x1500          | KI-2500x1500<br>(option braked) | KI-3000x1500          | KI-3000x1500<br>(option braked) |
|-------------------------------|-----------------------|---------------------------------|-----------------------|---------------------------------|
| Unladen weight                | 405 kg                | 430 kg                          | 430 kg                | 455 kg                          |
| Gross weight                  | 750 kg                | 750 kg                          | 750 kg                | 750 kg                          |
| Loading capacity              | 345 kg                | 320 kg                          | 320 kg                | 295 kg                          |
| Number of axles               | 2                     | 2                               | 2                     | 2                               |
| Axle type                     | AL-KO 700-5           | AL-KO B-700-5                   | AL-KO 700-5           | AL-KO B-700-5                   |
| Overrun brake                 | ---                   | 1637                            | ---                   | 1637                            |
| Coupling device               | ---                   | AL-KO 90S                       | ---                   | AL-KO 90S                       |
| Coupling device               | Steelpress ZSK-750    | AL-KO AK 161                    | Steelpress ZSK-750    | AL-KO AK 161                    |
| Drawbar                       | BW 2700               | BW 2700                         | BW 2700               | BW 2700                         |
| Tyre size                     |                       |                                 |                       |                                 |
| standard                      | 155/80R13             | 155/80R13                       | 155/80R13             | 155/80R13                       |
| optional - low profile tyre   | 195/50 B10            | 195/50 B10                      | 195/50 B10            | 195/50 B10                      |
| Internal dimensions (LxWxH)   | 2500 x 1500 x 350 mm  | 2500 x 1500 x 350 mm            | 3000 x 1500 x 350 mm  | 3000 x 1500 x 350 mm            |
| Overall dimensions (LxWxH)    | 3840 x 1630 x 1680 mm | 3840 x 1630 x 1680 mm           | 4375 x 1630 x 1680 mm | 4375 x 1630 x 1680 mm           |
| Cylinder (3 stage)            | Penta BL335 785 75 3  | Penta BL335 785 75 3            | Penta BL335 785 75 3  | Penta BL335 785 75 3            |
| Lifting mechanism             |                       |                                 |                       |                                 |
| standard - hand pump          | FULCRO PMI 25-S/3     | FULCRO PMI 25-S/3               | FULCRO PMI 25-S/3     | FULCRO PMI 25-S/3               |
| oil tank capacity             | 3l                    | 3l                              | 3l                    | 3l                              |
| optional - electro pump group | Hydroven HY10         | Hydroven HY10                   | Hydroven HY10         | Hydroven HY10                   |
| oil tank capacity             | 8l                    | 8l                              | 8l                    | 8l                              |
| battery                       | Varta LED60           | Varta LED60                     | Varta LED60           | Varta LED60                     |
| Hydraulic oil                 | Wolf Arow ISO 46      | Wolf Arow ISO 46                | Wolf Arow ISO 46      | Wolf Arow ISO 46                |
| Max. tilting angle            | 40°                   | 40°                             | 40°                   | 40°                             |

**Please note:** the load capacity of each trailer is ultimately determined by the gross weight minus the unladen weight.

The gross weights of the trailers listed in this table may be further limited upon registration. This weight is stated on the certificate of conformity under item 17.1.

## Optional equipment and accessories

Flat cover



Jockey wheel



Frame + tarpaulin



Leaf rack



Spare wheel



Integrated aluminum ramps



13/7-pin adapter



Wheel chock



Manual winch



Anti-theft lock



1,5mm galva plate



Aluminum Superstructure



LED-lighting



Pivotable Prop stands



Electrical control + battery



## Electrical installation

### Connection 7-pole plug

| 7-pole plug   | Pin     | Colour | Function  |
|---|---------|--------|---|
|  | 1 / L   | Yellow | Indicator left  |
|   | 2 / 54g | Blue   | Fog light   |
|   | 3 / 31  | White  | Mass  |
|   | 4 / R   | Green  | Indicator right   |
|   | 5 / 58R | Brown  | Rear lights<br>Wide-beam headlamps<br>License plate light right |
|   | 6 / 54  | Red    | Break lights  |
|   | 7 / 58L | Black  | Rear lights<br>Wide-beam headlamps<br>License plate light left  |

### Lighting

Check the presence of the light fittings around the trailer.

Check for damage and operation, replace defective lamps or reflectors. Have defective lights, torn / pink electrical cables replaced in a specialist workshop.

Rear lights:  
Aspöck Multipoint V (5-pin)



Front marker (\*):  
Option 1 - Aspöck Flexipoint I



Side marker:  
Reflector amber



Option 2 - Aspöck Flatpoint II



(\*) from a trailer width >1600mm



### WARNING

Faulty rear / contour lights, marker / outline lights  
Road users cannot see the vehicle clearly - danger of accidents!  
Before setting off, check that all the lights on the trailer are working properly.



## Before setting off

- The driver of the towing vehicle must have a valid driving licence to drive the towing vehicle and the trailer.
- Ensure that the trailer lighting system functions correctly.
- Make sure the load is securely fastened.
- Check that moving parts of the trailer are secured against loss.
- Ensure that all trailer tyres are inflated to the correct pressure according to the table in paragraph 'Wheels and tyres'.
- Check the tyre profile of all trailer tyres.
- Observe the applicable rules and regulations regarding the maximum authorized mass (MAM) of the trailer as indicated on the type plate.



### Objects on the trailer body!

Objects such as branches, ice, snow, etc. that are on the roof can be hurled onto the road while driving. Therefore, remove all objects such as branches, ice, snow and water from the trailer body before setting off.

### Worn tyre profile and / or incorrect tyre pressure!

The tyres may burst during the journey, causing the trailer to sway, tilt and break loose from the towing vehicle. The braking distance will become longer.

## Coupling

The trailer is connected to the towing vehicle by means of the ball coupler. The ball coupler is part of the trailer's towing device. It may only be used in a fully assembled and tested system to connect the trailer to the towing vehicle.

There are a number of steps you must follow when attaching a trailer to a towing vehicle. These steps are listed below and must be followed in chronological order.

- Check the condition of the auxiliary coupling cable (for unbraked trailers) or the breakaway cable (for braked trailers) - replace it before using the trailer if it is frayed, kinked or missing.
- Check that the ball is clean and that the coupling head is sufficiently greased.
- Make sure the trailer is on a level surface and (for braked trailers) that the parking brake is activated.
- If optional jockey wheel present - make sure the jockey wheel lock is securely fastened - turn the jockey wheel up and lift the coupling to a height greater than that of the tow ball.
- Turn the towing vehicle backwards so that it is in line with the trailer and the coupling head is directly above the tow bar.
- Attach the auxiliary coupling cable (unbraked trailers) or breakaway cable (braked trailers) to the towing vehicle.

- Press the release button and lift the lever. Lower the coupling onto the tow bar and release the lever.
- If optional jockey wheel present - pull in the jockey wheel and make sure that the wheel is fully retracted and (only for braked trailers) free of the brake rod.
- Connect the lighting plug and check that all the lights are working correctly.
- Release the parking brake of the trailer (only for braked trailers).



After each coupling, check that the ball coupler is securely attached to the tow bar of the towing vehicle. This can be done by means of a lifting test.  
Connecting the trailer with different ball couplers is basically the same.



**DANGER**

**Driving without a correctly coupled ball coupler!**

The trailer can become disconnected from your vehicle's ball hitch during the journey and will sway and tilt.

Failure to follow these steps may cause the trailer to come loose and cause an accident.



**WARNING**



**Danger of bruising / injuries during coupling!**

During manoeuvring and coupling, you may be hit or trapped by the coupling.  
When coupling on a slope, always use a wheel lock and the parking brake if fitted..



You can get trapped with your hand or fingers between the tow ball coupling and the vehicle's ball coupler.

## Swivelling capacity of the ball coupler



Before setting off, check that the coupling of your vehicle allows the necessary swivelling in horizontal and vertical direction.  
Maintain a swivel range of vertical +/- 25° and horizontal +/- 20°..



### Limited swivelling!

Short tow bars with little freedom of movement for the ball coupler can limit the necessary turning movement during the ride. T  
The trailer can become disconnected from your vehicle's ball hitch and will sway and tilt.

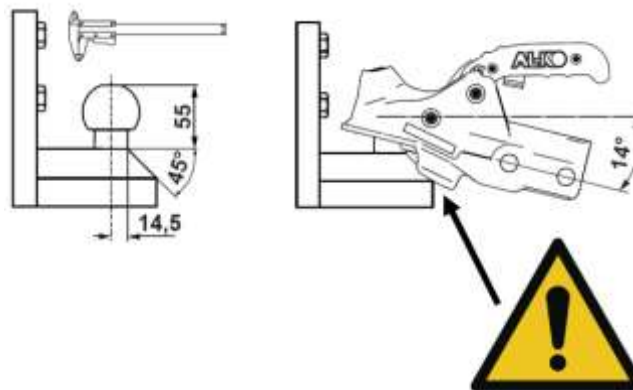

Only use a ball coupler according to Directive 94/20/EC, ECE R55 with a ball head of Ø 50 mm and a ball coupler according to DIN 74058 or ISO 1103.

## Coupling height of ball coupler



Before coupling your trailer for the first time, check that the height of the vehicle's ball head complies with the normalised height of  $430 \pm 35$ mm. The measured height must be within the range 395 - 465 mm between the road surface and centre ball head.

- If the measurement difference is too great, adjust the height of the vehicle's ball hitch.
- If necessary, have another ball hitch fitted to your towing vehicle in a specialist workshop.



### Incorrect coupling height!

Trailers that are not horizontal due to different coupling heights experience more wear at the coupling. The required turning movement is limited. Driving behaviour is influenced, which increases the risk of swaying. The trailer can become disconnected from your vehicle's ball hitch and will sway and tilt.



### Driving with a worn / dirty ball coupler!

The trailer can become disconnected from your vehicle's ball hitch during the journey and will sway and tilt.



The ball head of the tow bar of your vehicle must be greased. This prevents premature wear and the appearance of grooves on the ball head and in the coupling housing (ball cap).



## Loading and unloading

When loading a trailer, it is best to connect the trailer to the towing vehicle with the trailer's parking brake (braked trailer) engaged

The user should place the load in the centre of the trailer and over the axle(s) as much as possible. This ensures an even distribution of the load, optimising the trailer's balance on the road and to achieve the best possible braking effect.

The centre of gravity of the load should be positioned over the axle(s) and as low as possible to optimise road holding. The load restraints used must comply with the EN 12915 standard.

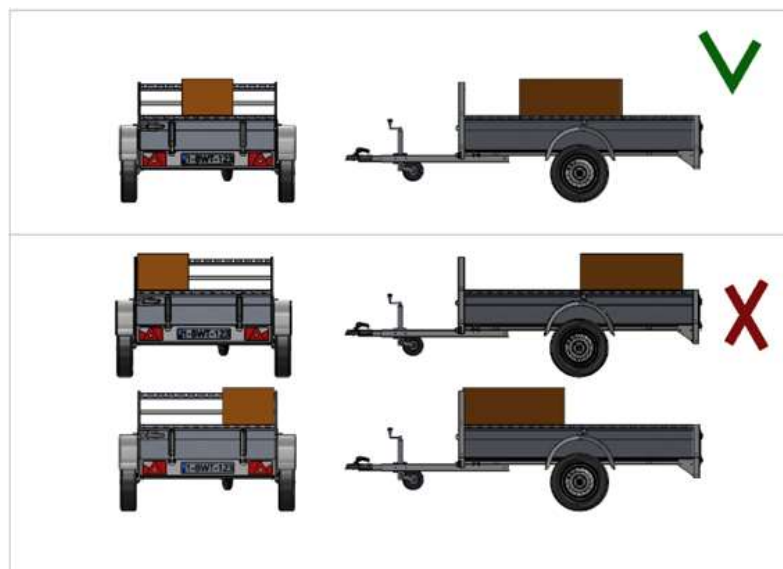

General points of attention :

- Make sure that no negative vertical load is created during loading of the trailer or that the maximum vertical load is not exceeded.
- To ensure good road holding, the centre of gravity of the load should be as close to the axles as possible and the load should be distributed between the left and right-hand halves of the trailer as evenly as possible. Concentrated loads should be avoided and large lighter loads should be distributed evenly.
- The load must be sufficiently secured to the intended points of attachment in accordance with national regulations.

## Driving the trailer

When towing a trailer, the following steps must be taken to ensure that your vehicle / trailer is positioned on the road as safely as possible.

- Before setting off, make sure that the ball coupler is fully engaged, that the auxiliary coupling cable (unbraked trailer) or break away cable (braked trailers) is connected, that the jockey wheel (if present) is fully retracted and locked and that the lights are all working.
- Make sure that the load in combination with the trailer does not exceed the gross weight of the trailer and is firmly secured in the centre of the trailer.
- Observe the rules and regulations in force with regard to the maximum authorised mass (MAM) of the trailer (MAM = unladen weight + load).
- Check the tyre pressure of the trailer in accordance with the values given in this manual.
- Never exceed the locally applicable towing speeds.
- The national regulations of each country must be respected.
- Make sure that no negative vertical load is created during loading of the trailer or that the maximum vertical load is not exceeded.
- If optional brakes are fitted - ensure that the drawbar is as flat as possible to avoid twisting.
- Passengers must not sit in or on the trailer while the vehicle and trailer are in motion.
- Always adjust your driving style and speed, depending on the road you are driving on.



### **DANGER**

#### **Excessive, not adjusted speed!**

The trailer can start to sway, tilt and become disconnected from the towing vehicle. The load safety device may come loose and the load may fall down.

#### **Poor road conditions / extreme weather conditions!**

The trailer can sway, tilt and become disconnected from the towing vehicle in case of uneven roads with potholes or in case of severe weather, e.g. storms, slippery conditions due to snow, ice and hail.

#### **Gusts / winds!**

The trailer can sway, tilt or become disconnected from the towing vehicle during abrupt steering movements due to gusts/winds that can occur at bridges, tunnels, forest firebreaks, noise barriers or when overtaking trucks.

#### **Too high load / structure!**

A load / structure that is too high can snap when passing through tunnels, under bridges, in underpasses, etc. Before departure, check that the maximum permitted total height is not exceeded. Before entering a tunnel, underpass or bridge, pay attention to the road signs with the maximum permissible vehicle height.

## Uncoupling

Open the coupling lever and lift the ball coupling of the tow bar ball from the towing vehicle. With higher ball pressures, lifting and lowering can be made easier by using a jockey wheel.

Make sure an unbraked trailer is on a level surface. If this is not the case, use wheel chocks.

Apply the parking brake (braked trailer) to prevent the uncoupled trailer from rolling away.

Remove the plug for the lighting.

Disconnect the auxiliary coupling (unbraked trailer) or break away cable (braked trailers) from the towing vehicle.



**Risk of injury! The trailer can roll back!**

When uncoupling or parking on a slope, always use a wheel lock.

If optional brakes are fitted - until the full braking force is applied, the trailer can roll back 25-30 cm!

When parking the trailer, ensure that there is sufficient distance.

## Ball coupling for unbraked trailers

### Ball coupler components for type ZSK-750 / AK7V

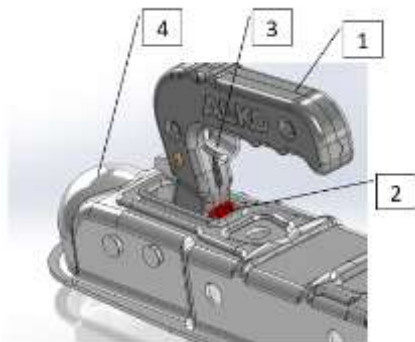

1. Coupling lever
2. Wear indicator (only AK7V)
3. Locking handle
4. Semi-ball shaped cap

### Coupling operation

Push the locking lever upwards with your index finger (1) and lift the coupling lever forwards (2) (open).

Put the open coupling with the handle pulled upwards on the ball and push it downwards by hand.

The coupling closes by applying light pressure.

The coupling mechanism is securely locked when the coupling lever cannot be pushed further down by hand.

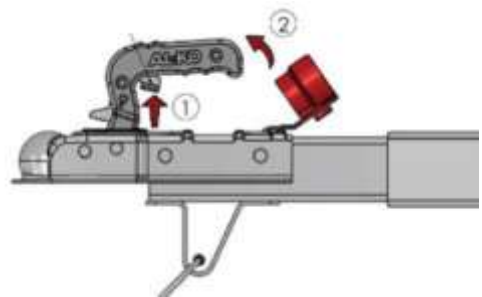

Observe the permissible weight (max 75kg)!

In any case, it must be checked that the ball coupler is correctly positioned on the ball.



## The wear indicator (only AK7V)

The wear indicator on the coupling lever shows:

- Tow ball wear limit
- Ball coupler wear limit

To check wear-and-tear, the trailer must be connected to the towing vehicle.

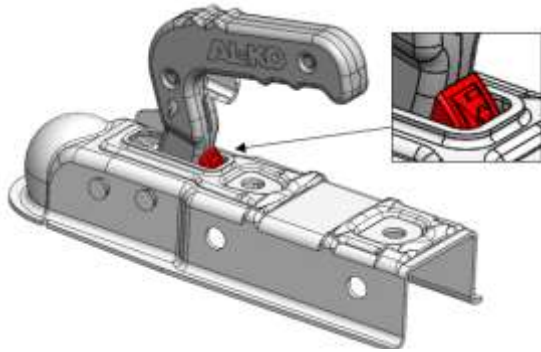

Marker shows a red range (+) :

- Ball coupler in new condition.
- The wear of the tow ball of the towing vehicle is within the permissible range.

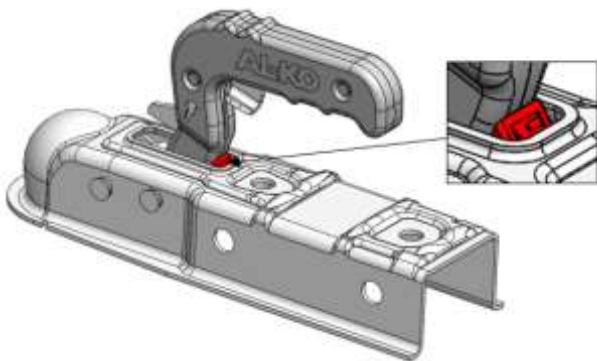

Marker shows a red range (-) :

- Ball coupler at the extreme wear limit  $\varnothing$  49mm or smaller (no wear on tow ball).
- Tow ball is in new condition  $\varnothing$  50 mm (ball coupler shows increased wear).
- Ball coupler and tow ball show wear-and-tear.



Driving with ball coupler and / or tow ball showing a high level of wear-and-tear!  
While driving, the ball coupler can slip off, causing the trailer to become detached from the towing vehicle.  
Have the ball coupler and tow ball checked immediately!  
Have the worn part replaced immediately.



## Auxiliary coupling for unbraked trailers

The auxiliary coupling cable prevents the trailer from disconnecting from the towing vehicle in the event that the trailer becomes detached from the ball coupling while driving so that the trailer cannot roll away uncontrolled.

Lock the auxiliary coupling cable in the clamping device after connecting the ball hitch.

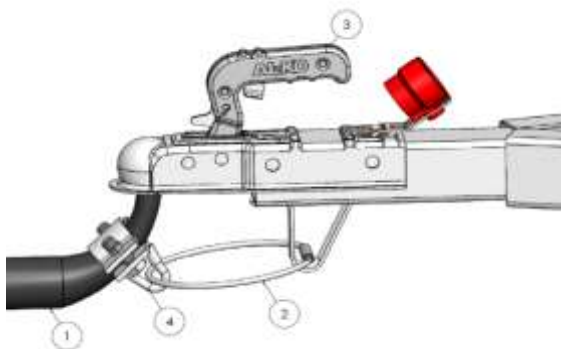

Components:

1. Ball hitch of towing vehicle
2. Auxiliary coupling cable
3. Ball coupler of trailer
4. Clamping device



### DANGER

#### Driving without the auxiliary coupling cable!

The trailer can become disconnected from your vehicle's ball hitch during the journey and will sway and tilt.

#### Driving with incorrectly installed auxiliary coupling cable!

The auxiliary coupling cable may come off while driving. In case of uncoupling, the trailer would not be secured, danger of accidents.



### ADVICE

Install the auxiliary coupling in such a way that negotiating bends is possible without any problems.

The auxiliary coupling must not wrap itself around the jockey wheel.

When installing the auxiliary coupling, observe the country-specific regulations.



The Netherlands and Switzerland are the only European countries that have rules for the installation of the auxiliary coupling cable. In both countries, the auxiliary coupling twisting around the ball neck is considered an offence. In the case of police checks, this can lead to high fines.

## Wheels and tyres

Wheels and tyres are important safety components on the trailer. They directly increase the driving comfort and improve the driving behaviour of the trailer.

Visually inspect the wheels regularly and replace if:

- cracks can be seen in the rim or tyre.
- the rim shows deformation.
- the bolt holes are deformed.
- there is considerable rust formation between the tyre and the rim.
- wheel bolts are broken.



The wheel size shall be appropriate to the type of trailer and shall not be changed as such. The permitted wheel / tyre size can be found on the COC document of the trailer under point 35. Defective wheels must be replaced immediately! Do not take any safety risks!

As the tyres are subject to permanent wear while driving and to ageing, they must be checked regularly.

Regularly check:

- Tyre pressure in cold condition
- Tread depth of the tyre in the centre of the tread.  
This must be at least 1.6 mm.



Weather conditions, including sunshine, cold weather, etc. will greatly influence the life of tyres. Tyres must not be older than 6 years after production date.

When replacing tires, take into account the load and speed index stated on the tyre.

The load index is given in a numerical code, corresponding with the maximum load that a tire can bear.

The speed index is indicated in a letter code corresponding the maximum speed of the tire.

| Tyre       | Max.<br>Tyre pressure<br>(bar) | Speed<br>index | Max.<br>speed<br>(km/h) | Load<br>index | Max.<br>load<br>(kg) |
|------------|--------------------------------|----------------|-------------------------|---------------|----------------------|
| 155/80R13  | 2.4                            | N              | 140                     | 78            | 615                  |
| 165R13C    | 4.6                            | N              | 140                     | 96            | 710                  |
| 185R14C    | 4.5                            | N              | 140                     | 104           | 900                  |
| 195/50B10  | 6.0                            | N              | 140                     | 98            | 750                  |
| 195/50R13C | 6.5                            | N              | 140                     | 104           | 900                  |
| 185/60R12C | 6.5                            | N              | 140                     | 104           | 900                  |

Conversion bar / psi / kPa:

- 1 psi = 0.0689 bar
- 1 bar = 14.504 psi
- 1 kPa = 0.01 bar



The maximum tyre pressure applies to both empty and fully loaded trailers.



## WARNING

### Wheel bolts come undone!

Wheels can come off while driving - danger of accidents!

Tighten the wheel bolts alternately after the first 50 km and after each wheel change.

Regularly check the tightness of the wheels with a torque wrench (tightening torque 100 Nm).

### Worn tyre profile or incorrect tyre pressure!

Wheels can burst while driving - danger of accidents!

Longer braking distance - danger of swaying!

Check tyre pressure regularly.

Check the tread depth (< 1.6 mm = tyre replacement).

### Imprudence in traffic!

When changing a wheel, you can obstruct the flow of traffic - danger of accidents!

You can get hit by passing vehicles!

Make the location on the road secure by placing a warning triangle. Use protective clothing.



## CAUTION

### Hot brakes (braked trailers)

You can burn yourself on hot brakes when changing wheels.



Let the brakes cool down before changing a wheel. Wear protective gloves!



## ADVICE

### Driving with incorrect tyre pressure

The tyres wear out excessively.

Before departure and at the latest after 14 days, check the tyre pressure in cold condition.

## Hydraulic lift function

When using the tipping mechanism, observe the following instructions before starting the procedure:

- The person operating the tipper has read and understood the instructions for operating the tipper.
- No one should stand on or near the trailer while tipping, except the person with the relevant expertise to operate the tipper.
- The trailer must be stationary and correctly coupled to the towing vehicle. The use of supports and wheel wedges is recommended if stability cannot be guaranteed without these items.
- The ground under the trailer must be sufficiently stable to allow safe execution of the tipping movement. If this is not the case, measures must be taken to ensure the ground is stable. The tipping movement must not be carried out on a surface that is too steep.
- The tipper must be able to carry out the tilting movement safely and without hindrance. Be careful not to get trapped between the bucket and the frame or side, front and rear flaps during tipping.
- Do not use the tipper in potentially explosive places.
- Hoses, attachment points, oil and battery (if applicable) must be checked for soundness, completeness and usability before the tipping function is activated.
- Ensure adequate lighting at the workplace during activities.
- The lighting on the trailer is not (clearly) visible during tipping. Take measures to compensate for this, for example by placing a warning triangle or warning lights behind the vehicle when tipping on public roads.



Trailers with optional electric pump group - If the trailer's tipping function is not used, the power supply must be interrupted to prevent unintended (re)activation. The power supply can be interrupted on the control box by setting the switch to the "0" position using a red key.



## Hydraulic lift function control

1. Turn the (optional) jockey wheel downwards.
2. Detach the load if it is still strapped in.
3. Open the tailgate of the bucket.
4. Unlock the upper frame of the undercarriage if applicable.
5. **Tipping trailer with hand pump (standard equipment)**
  - a. To lift the bucket, move the hand pump switch to the "lift" position and pump with the pump rod until the desired height is reached.
  - b. To lower the bucket, move the hand pump switch to the "lowering" position until the bucket is back on the chassis.
  - c. After completion, return the switch to the "lift" position.
5. **Tipping trailer with electric pump (optional)**
  - a. Turn the main power switch key clockwise to turn on the electrical installation.
  - b. To lift the bucket, press the white button until the desired height is reached.
  - c. To lower the bucket, press the black button until the bucket is back on the chassis.
  - d. Turn the key of the main power switch counter-clockwise to turn off the electrical installation.
6. Close the tailgate of the bucket.
6. Turn the jockey wheel up (optional).

## Floor support loading floor

Support the deep loading floor with the floor support during delays or during maintenance work on the trailer.

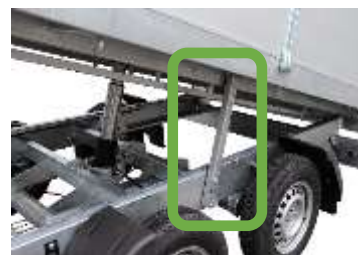

## Hazard zones during tipping



(\*) models with optional electric operation

### **DANGER**



#### Danger of crushing between chassis and loading floor!

You can get trapped between the chassis and the loading floor if the floor support is not used correctly.



#### Standing under an unsecured trailer!

The trailer may start to move, slide off the lifting device and tilt - danger of crushing!  
Secure the trailer against rolling away by means of wheel blocks - place them under intact wheels.



Before changing a wheel, check that the trailer is on a flat and firm surface. If necessary, use a firm underlay under the lifting mechanism.

Apply the parking brake if fitted.

Do not go under the trailer if it is not stable or if you are using an unsuitable/unsecure lifting device.

Keep other helpers away from a raised/unstable trailer.

## Cleaning

The trailer can be cleaned with water. If you use a high-pressure cleaner, the following rules must be observed:

- Distance to surface min. 70 cm
- Water pressure max. 50 Bar
- Water temperature max. 80 °C



During cleaning, the electrical components must not come into contact with water.



Do not clean the following parts directly with a high-pressure cleaner:

- Coupling and parking brake (optional)
- Lighting, plugs and cables
- Marking stickers
- Tyres
- Hydraulic components (only for tippers)

## Galvanised parts

The galvanised parts of the trailer (e.g. chassis, drawbar) must first oxidise to develop a corrosion-resistant effect. This may take several months. Only when the surface loses its zinc shine, is an anti-corrosion layer created.

A white rust can form on these parts. These are zinc oxides that form from moisture on galvanised parts. In order to avoid the formation of rust as much as possible, air must circulate sufficiently during storage so that no water film can form between the metal surfaces. Incidentally, the protective effect of the zinc layer is not reduced by the stains. White rust does not constitute damage and is, therefore, no reason to submit a claim.



Galvanised parts are not resistant to salts and acids (e.g. road salt, brine, fertilisers). Clean and dry the galvanised parts after contact with aggressive substances.



## Aluminum parts

Aluminium parts profiles (e.g. side panels) have an anodised coating, which offers optimal protection against corrosion.

## Storage / Parking

If the trailer is not used for an extended period of time, the following storage instructions apply to avoid possible problems when the trailer is reused:

- If possible, park the trailer in a shed or building, otherwise cover with a tarpaulin.
- Park at a location with adequate thief protection.
- Park on a flat surface.
- Remove any load from the trailer before storing it.
- Lock the wheels of the trailer or apply the parking brake if fitted.
- Ensure there is sufficient ventilation in the loading space.

## End of life cycle

This trailer contains certain materials that can be harmful to the environment, such as tyres. These must be disposed of properly, according to local environmental regulations. The tyres must be disposed of at a waste point. The trailer as a whole must be taken to a local scrap yard.



## Troubleshooting

| <i>Defect</i>   | <i>Cause</i>   | <i>Solution</i>  |
|---|--|--|
| <b>COUPLING</b>                                       |  |  |
| Ball coupler does not click into place after coupling | Ball cross-section greater than Ø 50 mm  | Have tow ball replaced   |
|   | Insufficient pressure on ball  | Push ball coupler down manually  |
|   | Inside of ball coupler dirty   | Clean and lubricate ball coupler ; replace if necessary.   |
| Trailer cannot be uncoupled                           |  | Set up and uncouple the trailer and the car in the same direction of travel.   |
|   | Tow ball oval-shaped   | Lubricate or oil coupling mechanism  |
|   | Lock latch not pressed down  | Press down lock latch  |
| Too much play between ball hitch and ball coupler     | Ball coupler worn  | Replace ball coupler   |
|   | Swivel range exceeded  | Have tow ball replaced.  |
| <b>TRAILER LOAD</b>                                   |  |  |
| Trailer swaying                                       | Tyre pressure is set too high  | Reduce air pressure on all tyres. Observe the maximum air pressure values of the tyres.  |
|   | Excessive speed  | Reduce your speed slowly   |
|   | Centre of gravity of the load is too far to the rear.<br>Ball pressure is insufficient or negative | Correct the centre of gravity of the load to the front.<br>Correct the load distribution to ensure sufficient drawbar load is available. |
| Trailer is flapping                                   | Load is not secured  | Secure the load properly   |
|   | Cables or hoses become loose   | Have these secured in a specialized workplace  |
|   | Nose wheel is not sufficiently turned upwards, if at all   | Turn the nose wheel upwards and have damaged parts replaced  |
|   | Parking brake is still applied   | Release the parking brake (*)  |
|   | Cover is not closed  | Close the cover completely   |
|   | Concrete nets are not securely fastened  | Check the fastenings of the concrete nets  |
|   | Side panels are not properly closed or secured.  | Check the closures of the side panels  |
|   | Lubrication points are not sufficiently lubricated   | Lubricate all lubrication points   |
| A defective wheel bearing                             | Replace wheel bearing  |  |
| Trailer tends to move to the right or left            | Load is not evenly distributed   | Distribute load evenly   |
|   | Tyre pressure is uneven  | Adjust air pressure so that all the tyres have the same air pressure   |
|   | Load is not sufficiently secured (non-slip) and is moving slowly                                   | Align the load evenly and secure the load in a non-slip manner   |
|   | Brake of one wheel is incorrectly adjusted and brakes  | Have it adjusted correctly in a specialized workplace (*)  |

(\*) only for models with option braked

## Maintenance

Trailers must be inspected by a competent / qualified specialist for their safe working order as and when required, but at least once a year in normal use (max. 10,000 km per year). If necessary, the service interval must be adapted to your usage routine and operating conditions.

### Service obligations

The following work is the responsibility of the user / owner :

- Compliance with the manufacturer's prescribed maintenance intervals and service work.
- Regular maintenance / cleaning of the trailer of contaminations / foreign objects.
- Regular presentation of the trailer for technical inspection if required.



Failure to follow the maintenance instructions may reduce or invalidate the manufacturer's product liability or warranty!  
We recommend an inspection interval of 1 year.

Following maintenance work should be done periodically at regular intervals:

- Regular visual inspection / inspection of the trailer and components for damage, contamination and wear.
- Functional test of the trailer and of the individual components.
- Periodic lubrication work on grinding points and repair of individual parts.
- Adjusting / tightening of unscrewed screw / clamp connections.
- Repair of worn, defective, safety-relevant parts by qualified personnel in a specialist workshop.



As a user of the trailer, you may only carry out limited maintenance. Certain maintenance work may only be carried out by qualified personnel!

## Safety parts

Safety-relevant components are included:

- Axles
- Brakes and overrun brake (optional)
- Couplings
- Wheels / tyres
- Screw connections of supporting parts e.g. drawbar, axle connection
- Load floor support (only for tipper trailers)
- Hydraulic components - manual or electrical (only for tipper trailers)
- Attachments e.g. gas springs, wheel shock absorbers
- Electric systems e.g. lighting



For safety reasons, all safety-relevant components must be regularly checked and maintained by qualified personnel.

Damaged and non-functioning parts of the trailer must be replaced by original spare parts from BW Trailers BV.

The accident prevention and environmental regulations must be observed during all maintenance work.

## Maintenance intervals axles and bearing

### Maintenance intervals unbraked axle with ball bearing

Type: AL-KO 700-5

After 1.500 kms or 6 months

- Check the axial play of the wheel hub bearings and have them adjusted if necessary
- Check the quantity and condition of the grease and re-lubricate if necessary

### Maintenance intervals braked axle with ball bearing

Type: AL-KO B 700-5

After 1.500 kms or 6 months (first inspection)

- Check the axial play of the wheel hub bearings and have them adjusted if necessary
- Check braking system and adjust if necessary

Every 10.000 kms or 12 months

(wheel brake 1636G/1637: every 5.000 kms or 12 months)

- Check the axial play of the wheel hub bearings and have them adjusted if necessary
- Check the quantity and condition of the grease and re-lubricate if necessary

- Check the wear of the lining of the wheel brakes every (inspection hole). If necessary, have them adjusted, or replaced when less than 2mm

Every 30.000 kms or 24 months

(wheel brake 1636G/1637: every 10.000 kms or 24 months)

- Maintenance of the braking system
  - Check whether the movable parts in the brake drum are still optimal.
  - Replace brake shoes and any defective springs.
- A new crown nut must always be used to secure the brake drum



If the trailer is used permanently in mountainous areas, the trailer brake is exposed to greater wear. For commercial trailers, there is a risk that adjustments may have to be made earlier.

### Safety instructions for axles

- AL-KO axles may not be welded.
- The rim data must match the axle data (wheel connection, rim inset depth, wheel bolt data).
- The type designation must not be rendered illegible by paint or obscured by components



All necessary maintenance work may only be carried out by trained personnel in special workshops or service centres.

### Bearing maintenance

The bearings used are maintenance-free. If the bearings are damaged, replace the entire brake drum. The bearings are integrated in the brake drum.



In the case of trailers coming into contact with water, the wheel hub bearings must be greased shortly after the trailer has driven through the water (with the exception of the waterproof hub).



#### Spare parts are safety parts!

If no original AL-KO spare parts are used, the warranty and product liability will be invalidated. This means that we as a manufacturer are no longer liable for possible defects and consequences. The possibility of consequential damage and even physical injury should not be underestimated on the public roads. This must be taken into account when purchasing spare parts!

## Lubrication work

Use only the specified lubricants for lubricating and oiling the parts.

### Type of lubricants

- Multifunctional grease according to DIN 51825.
- Machine oil.

### Lubrication intervals

- Every 10.000 – 12.000 km or every 12 months



The lubrication intervals must be adjusted according to the intensity of use and the degree of contamination

### Lubrication points for ball couplers types ZSK-750 / AK7V (for unbraked trailers)

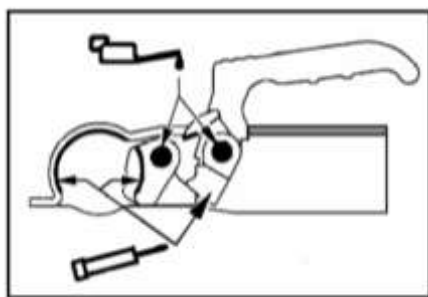

### Lubrication points for overrun device type 90S (for braked trailers)

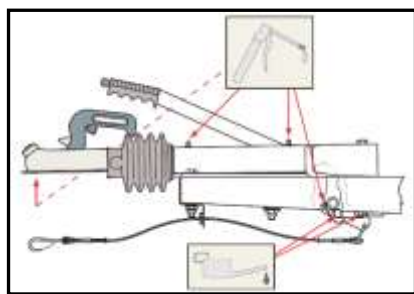

### Before lubricating

- Remove the old grease / waste oil completely from the lubrication points.
- Remove any contaminants.
- Clean the lubrication points and the lubrication nipples with a clean dry cloth.



## ADVICE

### Contaminated grease nipples.

Contaminants can enter the bearing and lead to increased wear.  
Clean the grease nipples before lubricating.

### After lubricating

Wipe away any excess grease or oil that has run out with a cloth.  
Check the parts are working properly.



## WARNING

### System failure due to faulty lubrication!

Some parts must not be lubricated / greased under any circumstances. The components may refuse to work - danger of accidents!

Find out which parts must not be lubricated, for example: clamp tubes on extendable support legs and jockey wheels, threads on wheel bolts, brake linings, etc.



## CAUTION

### Contact with lubricant

Lubricants can cause skin reactions.

Use only approved lubricants.

Use appropriate protective equipment.

Wash your hands thoroughly after the lubrication has been carried out.



## Service intervals and history

Observe the necessary maintenance and care instructions for the intended use. Have an inspection performed recorded and stamped.

| <i>First service</i>       | <i>1.000 km service</i>      | <i>5.000 km service</i>        |
|----------------------------|------------------------------|--------------------------------|
| Date                       | Date                         | Date                           |
| Stamp BW Trailers - dealer | Stamp BW Trailers - dealer   | Stamp BW Trailers - dealer     |
| Signature                  | Signature                    | Signature                      |
| Inspection on delivery     | max. 6 months after purchase | max. 1 year after last service |

| <i>10.000 km service</i>       | <i>15.000 km service</i>       | <i>20.000 km service</i>       |
|--------------------------------|--------------------------------|--------------------------------|
| Date                           | Date                           | Date                           |
| Stamp BW Trailers - dealer     | Stamp BW Trailers - dealer     | Stamp BW Trailers - dealer     |
| Signature                      | Signature                      | Signature                      |
| max. 1 year after last service | max. 1 year after last service | max. 1 year after last service |

| <i>25.000 km service</i>       | <i>30.000 km service</i>       | <i>35.000 km service</i>       |
|--------------------------------|--------------------------------|--------------------------------|
| Date                           | Date                           | Date                           |
| Stamp BW Trailers - dealer     | Stamp BW Trailers - dealer     | Stamp BW Trailers - dealer     |
| Signature                      | Signature                      | Signature                      |
| max. 1 year after last service | max. 1 year after last service | max. 1 year after last service |



| <i>40.000 km service</i>       |
|--------------------------------|
| Date                           |
| Stamp BW Trailers - dealer     |
| Signature                      |
| max. 1 year after last service |

| <i>45.000 km service</i>       |
|--------------------------------|
| Date                           |
| Stamp BW Trailers - dealer     |
| Signature                      |
| max. 1 year after last service |

| <i>50.000 km service</i>       |
|--------------------------------|
| Date                           |
| Stamp BW Trailers - dealer     |
| Signature                      |
| max. 1 year after last service |

| <i>55.000 km service</i>       |
|--------------------------------|
| Date                           |
| Stamp BW Trailers - dealer     |
| Signature                      |
| max. 1 year after last service |

| <i>60.000 km service</i>       |
|--------------------------------|
| Date                           |
| Stamp BW Trailers - dealer     |
| Signature                      |
| max. 1 year after last service |

| <i>65.000 km service</i>       |
|--------------------------------|
| Date                           |
| Stamp BW Trailers - dealer     |
| Signature                      |
| max. 1 year after last service |

| <i>70.000 km service</i>       |
|--------------------------------|
| Date                           |
| Stamp BW Trailers - dealer     |
| Signature                      |
| max. 1 year after last service |

| <i>75.000 km service</i>       |
|--------------------------------|
| Date                           |
| Stamp BW Trailers - dealer     |
| Signature                      |
| max. 1 year after last service |

| <i>80.000 km service</i>       |
|--------------------------------|
| Date                           |
| Stamp BW Trailers - dealer     |
| Signature                      |
| max. 1 year after last service |

## Warranty and liability

All our trailers come standard with a 24-month warranty.

### Warranty conditions

- The warranty only applies to defects that occur during normal use of the trailer and that are caused by inferior construction or materials, or by poor workmanship on the part of the manufacturer.
- Defects or imperfections in the goods delivered must be reported in writing to a recognised BW Trailers dealer as soon as possible, but no later than eight days after they have been discovered or when they could have been discovered.
- The report must also contain as detailed a description as possible of the defect, so that the recognised BW Trailers dealer and the manufacturer are able to respond adequately.
- If a defect is subsequently reported, the owner / user shall no longer be entitled to repair, replacement or compensation, unless a longer period is involved due to the nature of the case or the circumstances of the case.
- The guarantee consists of free replacement or repair of the defective product or parts thereof by the manufacturer or an authorised BW Trailers dealer.
- The warranty conditions of the respective supplier apply to installed third-party components. The warranty period may differ from that stated above.

### The warranty claim lapses, among others, if

- the defect is the result of normal wear-and-tear, improper or incorrect use, use of tools other than those prescribed, or injudicious or incorrect maintenance.
- the defect occurs after modifications or repair by or on behalf of the buyer / user himself or by third parties and if it concerns a defect in the jockey wheel of the trailer.
- the condition of the trailer at takeover (by means of a handover check by the dealer) cannot be demonstrated.
- the service intervals (service after x months) are not demonstrable.

### Liability

The manufacturer is not liable for unsafe situations, accidents and damage resulting from ignoring warnings or regulations such as:

- Improper or incorrect use or maintenance.
- Use for purposes or under conditions other than those specified in this documentation.
- The use of parts other than those prescribed.
- Repairs without the manufacturer's permission.
- Changes to the trailer, such as:
  - changes in the steering mechanism.
  - Welding, machining, etc.
  - Extensions on the trailer or steering system.
- If the customer has not met all the obligations towards the manufacturer (financially or otherwise).

## Annex I - EG-declaration of conformity

### EG VERKLARING VAN OVEREENSTEMMING

BW Trailers BVBA

Walemstraat 94 A-B, 2570 Duffel, België

Hierbij verklaren wij, dat de aanhangwagens van de onderstaande types, geproduceerd door BW Trailers bvba en uitgerust met een specifieke hydraulische kipinrichting ter behoeve van het kippen van de last zoals die zich op de aanhangwagen bevindt, in overeenstemming is met de geldende Europese richtlijnen en normen.

Betreffende de aanhangwagens van het type:

- Kipper (KI)
- Tiltbed (TB)

Het onderzoek heeft plaatsgevonden met in acht name van de volgende Europese Normen:

|                           |   |
|---------------------------|---|
| NEN EN 1853:1999+A1: 2009 | Landbouwmachines. Kipwagens. Veiligheid   |
| NEN-EN 4413: 2010         | Hydrauliek Algemene regels en veiligheidseisen voor systemen en hun componenten                               |
| NEN_EN 349+A1: 2008       | Veiligheid van machines – minimum afstanden ter voorkoming van het bekneld raken van menselijke lichaamsdelen |
| NEN-EN-ISO 12100-1: 2010  | Veiligheid van machines – Basisbegrippen voor ontwerp – Risicobeoordeling en risicoreductie                   |

Volgens de bepalingen van de Europese Richtlijnen:

MRL-2006/42/EC en in voorkomende gevallen de EMC-2014/30/EC

Plaats: Duffel

Datum: 30/05/2018

Naam: Bjorn Willems

Handtekeningen:

