



Tipper Tridem series

Operating instructions for all Tipper Tridem series trailers with a weight class of 2.500kg to 3.500kg.

Table of Contents

<i>Foreword</i>	3
<i>Identification</i>	3
<i>Confirmation of conformity</i>	4
<i>Productnames</i>	4
<i>Safety and warning instructions</i>	5
<i>Technical data</i>	10
<i>Nameplate / VIN number</i>	10
<i>Overview of trailer components</i>	12
<i>Technical specifications</i>	13
<i>Optional equipment and accessories</i>	14
<i>Electrical installation</i>	15
<i>Before setting off</i>	16
<i>Coupling</i>	16
<i>Loading and unloading</i>	20
<i>Driving the trailer</i>	21
<i>Uncoupling</i>	22
<i>Ball coupler braked trailers</i>	23
<i>Overrun device with parking brake</i>	27
<i>Wheels and tyres</i>	29
<i>Hydraulic lift function</i>	31
<i>Cleaning</i>	34
<i>Storage / Parking</i>	35
<i>End of life cycle</i>	35
<i>Troubleshooting</i>	36
<i>Maintenance</i>	38
<i>Service intervals and history</i>	42
<i>Warranty and liability</i>	45

Foreword

Dear Customer,

Congratulations on your purchase of a trailer from BW Trailers.

This Owner's Manual contains all the operating and safety instructions that apply to the trailer. For safety reasons, it is absolutely necessary that you read these instructions carefully in order to guarantee safety for yourself and others before you take the trailer on the public roads.

The maintenance instructions for the trailer are also included in this documentation and must be followed and carried out correctly in order to qualify for the warranty conditions.

If there are any questions after you have read the documentation, you can always contact the manufacturer or dealer for further explanation or information.

The Owner's Manual is part of the trailer and should therefore be kept in a safe place. In case of resale, the Owner's Manual must always accompany the trailer. Extra copies can always be obtained from a dealer or downloaded from our website.

Identification

This documentation was drawn up in Dutch by BW Trailers BV.

Version designation:	Operating instructions KI-series
Version date:	November 2023
© Copyright:	BW Trailers BV, Duffel, 2023

No part of this documentation may be reproduced in any form without the prior permission of BW Trailers BV.

BW trailers BV

Walemstraat 94 A-B
2570 Duffel
Belgium
Tel: +32 (0)15 34 18 10
Fax: +32 (0)15 34 18 19
Mail: info@bwtrailers.be
Web: www.bwtrailers.be

Confirmation of conformity

The trailer complies with the requirements of the European Directive 2007/46/EC for which the RDW has granted the necessary type approvals.

Furthermore, the manufacturer BW Trailers BV confirms compliance with all relevant EC directives that apply to the hydraulically tipping part of the trailer in terms of health and safety.

Productnames

Tick the type of trailer you have purchased.

Triple axle trailers 3 x 1500 kg - BRAKED			
	MAM		MAM
	3500 kg		3500 kg
Standard tyre		Low profile tyre (optional)	
KI-4000x2000-3A-350BTG-E	<input type="checkbox"/>	KI-4000x2000-3A-350BTG-E-LP	<input type="checkbox"/>

Triple axle trailers 3 x 1800 kg - BRAKED			
	MAM		MAM
	3500 kg		3500 kg
Standard tyre		Low profile tyre (optional)	
KI-4000x2000-3A-350BTG-E	<input type="checkbox"/>	KI-4000x2000-3A-350BTG-E-LP	<input type="checkbox"/>

Safety and warning instructions

In order to recognise certain information in this manual more quickly and easily, text and images are indicated with certain symbols, signal words and highlighted text.

Hazard warnings



This instruction indicates an imminently hazardous situation which, if not avoided, may result in death or serious injury.

Here you can read what the hazard is, what consequences it can have for you and what you need to do to avoid it.

Observe special precaution.



This instruction indicates a potentially hazardous situation which, if not avoided, may result in death or serious injury.

Here you can read what the hazard is, what consequences it can have for you and what you need to do to avoid it.

Observe special precaution.



This instruction indicates a potentially hazardous situation which, if not avoided, may result in minor or moderate bodily injury or damage to property.

Here you can read what the hazard is, what consequences it can have for you and what you need to do to avoid it.

Observe special precaution.



This instruction indicates possible damage to property if the hazard is not avoided.

Here you can read what the hazard is, what consequences it can have for you and what you need to do to avoid it.

Observe special precaution.

Hazard symbols indicating particular sources of danger



Warning of dangerous place!
Be careful - several causes can lead to dangers for humans.



Risk of bruising!
People's limbs such as hands / fingers / feet can be bruised.



Risk of bruising / knocks / of being hit!
Persons can be bruised, knocked, hit or generally injured.



Risk of chemical burns!
People can get burns through contact with toxic substances.



Risk of burns!
People can burn themselves on hot surfaces



Danger when handling batteries!
Persons may be injured by leaking battery acid or short circuits



Risk of electric shock, dangerous voltage!
Dangerous voltage can be fatal.



Risk of environmental pollution!
The environment can be polluted when hazardous substances are used incorrectly.

Mandatory signs



Important instruction - observe!
Indicates important information that must be observed and complied with for safe operation.



Read the Owner's Manual!
It is important to read the Owner's Manual before performing the activity.

Personal protective equipment



Safety shoes, sturdy footwear!



High visibility clothing, safety vest!



Protective gloves!



Protective mask, respiratory protection!



Apply hand protection!
Apply hand protection on your hands before / after the activity.



Wash hands!
Wash your hands thoroughly after the activity has been carried out

Prohibition Signs



Unauthorised access is prohibited! Keep people at a distance!
Keep people away from the danger zone.



Do not spray with water!
Prevent water jets from being sprayed directly onto vulnerable parts of your trailer.



Entry area / zone prohibited!
Never enter the danger zone / hazardous area during work.

Other important pictograms



Proper disposal of waste oil!
Dispose of the waste oil properly.
Do not dispose of waste in the environment!



Proper disposal of old tyres!
Dispose of used tyres properly.
Do not dispose of waste in the environment!



Problematic waste!
Dispose of the parts properly.
Do not dispose of any waste in the environment or in household waste!!

Warnings on the trailer

	<p>Als de trailer in stilstande toestand wordt geladen of gelost kan het voorkomen dat de zichtbaarheid van de verlichting en markering niet voldoen aan de wettelijke voorschriften. Plaats een gevarendriehoek om andere weggebruikers te waarschuwen!</p>
	<p>If the trailer is loaded or unloaded in a stationary state, the visibility of the lighting and marking may not comply with the statutory regulations. Place a warning triangle to warn other road users!</p>
	<p>Si la remorque est chargée ou déchargée à l'arrêt, il peut arriver que la visibilité de l'éclairage et du marquage n'est pas conforme aux exigences légales. Placez un triangle d'avertissement pour avertir les autres usagers de la route!</p>

	<p>VEILIGHEIDSVORSCHRIFTEN KIEPENDE TRAILERS</p> <ul style="list-style-type: none"> - Alleen aangekoppeld kiepen - Aanhangbewijzen niet losmaken met aangerokken handrem - Hou alle gevarenzones vrij! - Ontgrendel de nodige zijborden alvorens te kiepen. - Gekepte laadvloer onderhouden bij opeenhoud - Schakel de stroomtoevoer uit alvorens te rijden <p>SAFETY REGULATIONS FOR TIPPING TRAILERS</p> <ul style="list-style-type: none"> - Tilt only coupled - Do not operate the trailer with the parking brake applied - Keep all danger zones clear - Unlock the necessary side boards before tipping. - Support the buckled loading floor during delays - Switch off the power supply before driving <p>RÈGLES DE SÉCURITÉ POUR LES BENNES</p> <ul style="list-style-type: none"> - Basculer uniquement couplée - Ne faites pas fonctionner la remorque avec le frein de stationnement serré - Gardez toutes les zones de danger dégagées - Déverrouillez les panneaux latéraux nécessaires avant de basculer. - Soudenez le plancher de chargement basculé pendant un court laps de temps. - Coupez l'alimentation avant de conduire 	<p>Deze trailer werd geproduceerd in overeenstemming met de Machinerichtlijn 2006/42/EG en toevoegsels.</p> <p>This trailer was produced in accordance with the Machinery Directive 2006/42/EC and additives.</p> <p>Cette remorque a été produite conformément à la Directive Machines 2006/42/CE et ses additifs.</p> <p style="font-size: 2em; text-align: center;">CE</p> <p>Model: BW Trailers kipper / tipper / benne Type: HJ Voertuigidentificatienummer typeplaat Vehicle identification number: See type plate Numéro d'identification du véhicule: plaque signalétique Bouwjaar / Year of construction / Année de construction: 2018</p>
	<p>BW Trailers BVBA - Walemstraat 94 A-B - 2570 Duffel</p>	
	<p>Lees aandachtig de volledige gebruiksaanwijzing en veiligheidsvoorschriften alvorens de trailer in gebruik te nemen. Carefully read the complete operating instructions and safety instructions before using the trailer. Lisez attentivement le mode d'emploi complet et les règles de sécurité avant d'utiliser la remorque.</p>	

General safety instructions



The owner / operator must have read and understood the Owner's Manual of the trailer thoroughly and completely. Ignoring the safety instructions and not following the steps during operations can lead to accidents involving personal injury. Improper operation can cause serious injury to yourself.

In addition, as a road user, you are obliged to comply with all national and international regulations for driving a vehicle with a trailer.



You must also comply with your duties as the owner of a commercial vehicle. This means regular maintenance, care and the periodic presentation of the trailer for a technical general inspection.



Ignoring safety instructions / warnings

Ignoring the safety instructions / warnings and not following the steps can lead to accidents involving personal injury. Improper operation can cause serious injury to yourself and others.

Intended use

The trailer is intended for transporting general goods.

The bucket of a tipper can tip backwards or backwards + sideways using a manually or (optionally) electrically controlled hydraulic tipping system.



The trailer may only be operated by an adult, properly trained, in good physical condition.

Foreseeable misuse

The trailer is not suitable for:

- Transport of people or animals.
- Unloading of general cargo with the tipping system.
- The use as lifting device for both people and goods.
- Transporting hot materials.
- Carriage of hazardous chemicals subject to authorisation.
- Speeding in adverse weather conditions and / or poor driving surface.
- Use in a damaged condition which can lead to road traffic hazards and personal injury.



As the manufacturer, we accept no liability for personal injury or damage to property caused by foreseeable misuse.



Children playing near your trailer!

Trailers are no toys! Children cannot properly assess the dangers of a trailer and can injure themselves while playing with the trailer.

Do not let children play near your trailer unsupervised.
Keep children at a safe distance when manoeuvring your trailer.

The trailers are classified by type and may not be modified according to their permitted equipment!

Changes to the trailer, such as the use of an axle, another make of ball coupling or overrun brake (optional) or non-registered wheels / tyres will lead to loss of approval!

Technical data

The technical data of your trailer can be found on:

- The accompanying certificate of conformity
- The nameplate
- Type designation in the brochures and sales information on our website www.bwtrailers.be



The loss of the EC certificate of conformity must be reported to the police. A duplicate of these documents can be requested from the manufacturer with official proof of loss.

Nameplate / VIN number

Each trailer is provided with a nameplate that is permanently attached to the front of the trailer. It provides information about the origin, type and maximum weights of the trailer.

The unique 17-digit VIN number is also shown on the plate but is also engraved on the lower part of the chassis.

See the illustration below for the position of the nameplate and VIN number.

Position of the nameplate and VIN number

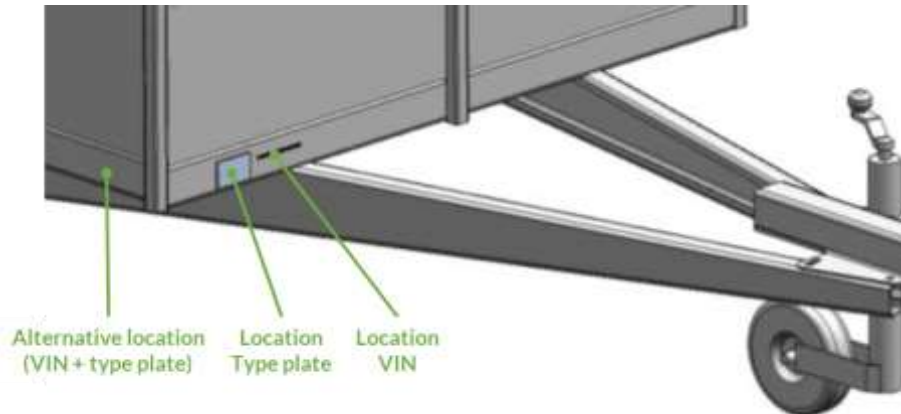

Example of type plate

BW TRAILERS BV			← Manufacturer name
e4*2018-858*00008			← EEC Type-approval number
			← 17-digit VIN (vehicle identification number)
	3500	kg	← Max. authorised mass
0-	350	kg	← Max. tow ball load
1-	1500	kg	← Max. permissible weight axle 1
2-	1500	kg	← Max. permissible weight axle 2
3-	1500	kg	← Max. permissible weight axle 3
Type: O2Tr			

↑ Category ECC-type approval



When contacting the manufacturer, you should always have the unique 17-digit VIN number to hand. On the basis of this number, the manufacturer can identify the trailer and request all linked specifications.

Overview of trailer components



- | | |
|--------------------------------|--|
| 1. Alu side board | 24. Tension lock |
| 2. Chassis | 25. Removable corner/intermediate post |
| 3. V-drawbar | 26. Wheel + tyre |
| 4. Coupling | 27. Axle |
| 5. Jockey wheel | 28. Integrated rope hook |
| 6. Hydraulic group + battery | 29. pivotable prop stand |
| 7. Hydraulic group control | |
| 8. Tipping cylinder | |
| 9. Power plug + holder | |
| 10. Auxiliary coupling | |
| 11. Ladder carrier | |
| 12. Overrun device | |
| 13. Floor support | |
| 14. Front positioning light | |
| 15. Storage compartment ramps | |
| 16. Spare wheel | |
| 17. Rear light left | |
| 18. Rear light right | |
| 19. Flexible positioning light | |
| 20. License plate light | |
| 21. Amber reflector | |
| 22. Loading floor | |
| 23. Flap hinge | |

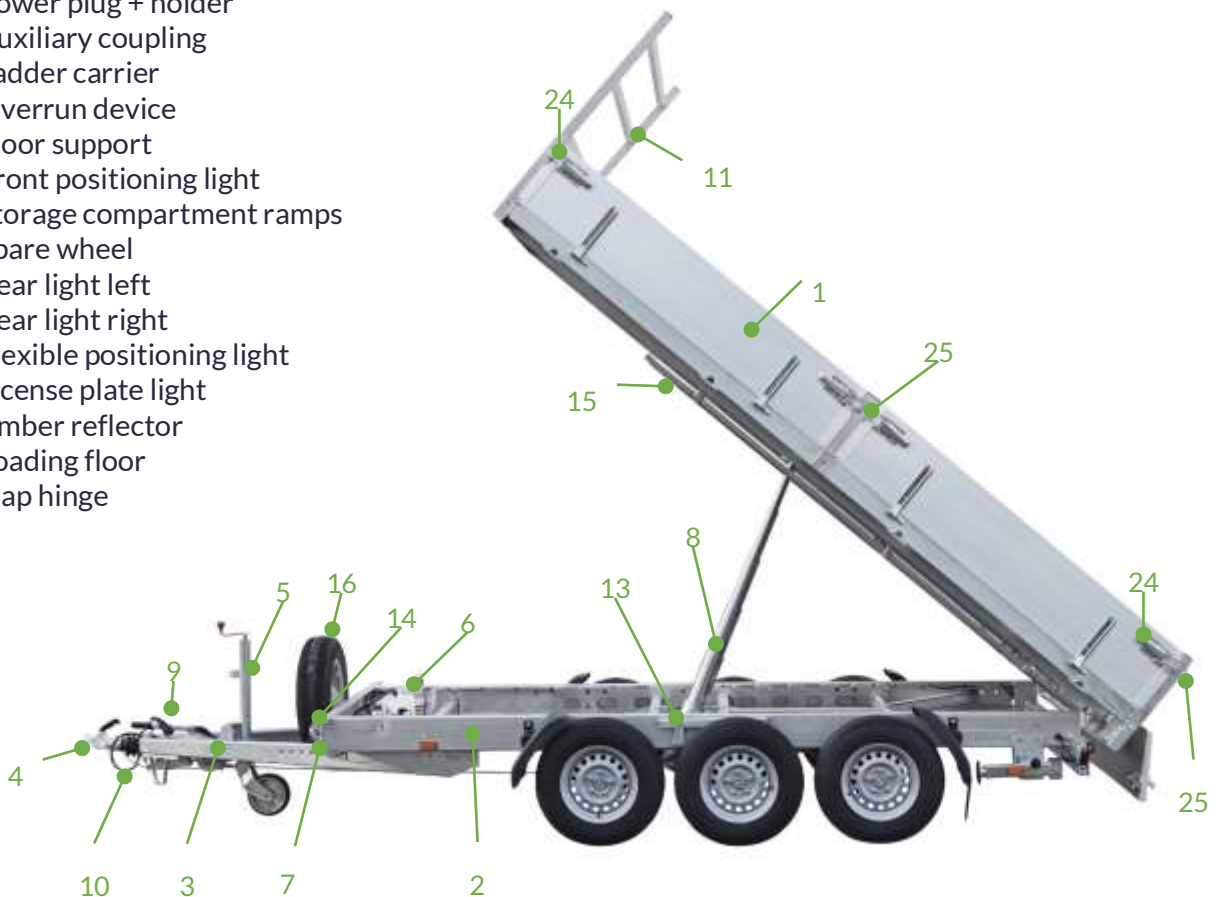

Technical specifications

	3 x 1500kg	3 x 1800kg
Unladen weight	1260 kg	1275 kg
Gross weight	3500 kg	3500 kg
Loading capacity	2240 kg	2225 kg
Number of axles	3	3
Axle type load (max)	AL-KO B 1600-3 1500 kg	AL-KO B 1800-9 1800 kg
Wheel brake	2051Ab	2361
Overrun brake	AL-KO AE 3500	AL-KO AE 3500
Coupling device	AL-KO AK351	AL-KO AK351
Drawbar	AL-KO 351T	AL-KO 351T
Tyre size standard optional	185R14C 185/60 R12C 195/50R13C	185R14C 185/60 R12C 195/50R13C
Internal dimensions (LxWxH)	4000x2000x350 mm	4000x2000x350 mm
Overall dimensions (LxWxH)	5500x2350x1925 mm	5500x2350x1925 mm
Cylinder 5 stage	Penta BL360 1435 105 5	Penta BL360 1435 105 5
Lifting mechanism electro pump group oil tank capacity battery	Hydroven HY10 12l Varta LED60	Hydroven HY10 12l Varta LED60
Hydraulic oil	Wolf Arow ISO 46	Wolf Arow ISO 46
Max. tilting angle	40°	40°

Please note: the load capacity of each trailer is ultimately determined by the gross weight minus the unladen weight.

The gross weights of the trailers listed in this table may be further limited upon registration. This weight is stated on the certificate of conformity under item 17.1.

Optional equipment and accessories

Leaf rack 650mm



Flat cover



Frame + tarpaulin



Pivotable Prop stands



Integrated aluminum ramps



Manual winch



7/13-pin adapter



Wheel chock



Anti-theft lock



Aluminum Superstructure



LED-lighting



Security hand pump



Electrical installation

Connection 13-pole plug

13-pole plug	Pin	Colour	Function
	1 / L	Yellow	Indicator left
	2 / 54G	Blue	Fog light
	3 / 31	White	Mass
	4 / R	Green	Indicator right
	5 / 58R	Brown	Rear lights Wide-beam headlamps License plate light right
	6 / 54	Red	Break lights
	7 / 58L	Black	Rear lights Wide - beam headlamps License plate light left
	8	Grey	Reverse lights
	9	Brown/blue	Permanent live wire
	10	Brown/red	Battery charging cable
	11	White/red	Mass for charging cable
	12	-	not in use
	13	White/black	Mass for permanent live wire

Lighting

Check the presence of the light fittings around the trailer.

Check for damage and operation, replace defective lamps or reflectors. Have defective lights, torn / pink electrical cables replaced in a specialist workshop..

Rear lights:
Aspöck Multipoint V



Front marker:
Option 1 - Aspöck Flexipoint I



Side marker (**):
Option 1 - Reflector orange



End outline marker (*):
Aspöck Superpoint II



Option 2 - Aspöck Flatpoint II



Option 2 - Aspöck Flatpoint



(*) vanaf een breedte > 2.100mm

(**) verlicht vanaf een lengte > 6.000mm



WARNING

Faulty rear / contour lights, marker / outline lights
Road users cannot see the vehicle clearly - danger of accidents!
Before setting off, check that all the lights on the trailer are working properly.

Before setting off

- The driver of the towing vehicle must have a valid driving licence to drive the towing vehicle and the trailer.
- Ensure that the trailer lighting system functions correctly.
- Make sure the load is securely fastened.
- Check that moving parts of the trailer are secured against loss.
- Ensure that all trailer tyres are inflated to the correct pressure according to the table in paragraph 'Wheels and tyres'.
- Check the tyre profile of all trailer tyres.
- Observe the applicable rules and regulations regarding the maximum authorized mass (MAM) of the trailer as indicated on the type plate.



DANGER

Objects on the trailer body!
Objects such as branches, ice, snow, etc. that are on the roof can be hurled onto the road while driving. Therefore, remove all objects such as branches, ice, snow and water from the trailer body before setting off.

Worn tyre profile and / or incorrect tyre pressure!
The tyres may burst during the journey, causing the trailer to sway, tilt and break loose from the towing vehicle. The braking distance will become longer.

Coupling

The trailer is connected to the towing vehicle by means of the ball coupler. The ball coupler is part of the trailer's towing device. It may only be used in a fully assembled and tested system to connect the trailer to the towing vehicle.

There are a number of steps you must follow when attaching a trailer to a towing vehicle. These steps are listed below and must be followed in chronological order.

- Check the condition of the auxiliary coupling cable (for unbraked trailers) or the breakaway cable (for braked trailers) - replace it before using the trailer if it is frayed, kinked or missing.
- Check that the ball is clean and that the coupling head is sufficiently greased.
- Make sure the trailer is on a level surface and (for braked trailers) that the parking brake is activated.

- If optional jockey wheel present - make sure the jockey wheel lock is securely fastened - turn the jockey wheel up and lift the coupling to a height greater than that of the tow ball.
- Turn the towing vehicle backwards so that it is in line with the trailer and the coupling head is directly above the tow bar.
- Attach the auxiliary coupling cable (unbraked trailers) or breakaway cable (braked trailers) to the towing vehicle.
- Press the release button and lift the lever. Lower the coupling onto the tow bar and release the lever.
- If optional jockey wheel present - pull in the jockey wheel and make sure that the wheel is fully retracted and (only for braked trailers) free of the brake rod.
- Connect the lighting plug and check that all the lights are working correctly.
- Release the parking brake of the trailer (only for braked trailers).



After each coupling, check that the ball coupler is securely attached to the tow bar of the towing vehicle. This can be done by means of a lifting test.
Connecting the trailer with different ball couplers is basically the same.

DANGER

Driving without a correctly coupled ball coupler!

The trailer can become disconnected from your vehicle's ball hitch during the journey and will sway and tilt.

Failure to follow these steps may cause the trailer to come loose and cause an accident.

WARNING



Danger of bruising / injuries during coupling!

During manoeuvring and coupling, you may be hit or trapped by the coupling.
When coupling on a slope, always use the parking brake if fitted or a wheel lock.



You can get trapped with your hand or fingers between the tow ball coupling and the vehicle's ball coupler.

Swivelling capacity of the ball coupler



Before setting off, check that the coupling of your vehicle allows the necessary swivelling in horizontal and vertical direction.
Maintain a swivel range of vertical +/- 25° and horizontal +/- 20°..



Limited swivelling!

Short tow bars with little freedom of movement for the ball coupler can limit the necessary turning movement during the ride. T
The trailer can become disconnected from your vehicle's ball hitch and will sway and tilt.

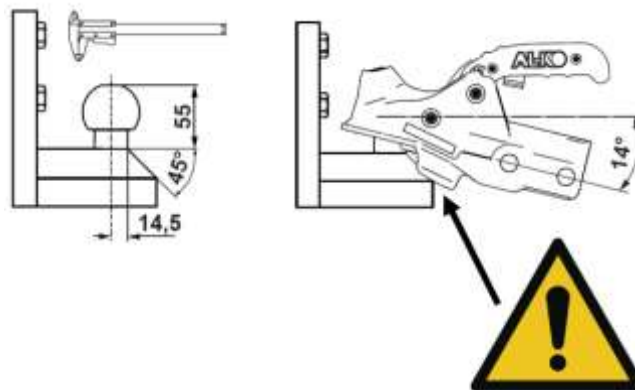

Only use a ball coupler according to Directive 94/20/EC, ECE R55 with a ball head of Ø 50 mm and a ball coupler according to DIN 74058 or ISO 1103.

Coupling height of ball coupler



Before coupling your trailer for the first time, check that the height of the vehicle's ball head complies with the normalised height of 430 ± 35 mm. The measured height must be within the range 395 - 465 mm between the road surface and centre ball head.

- If the measurement difference is too great, adjust the height of the vehicle's ball hitch.
- If necessary, have another ball hitch fitted to your towing vehicle in a specialist workshop.



Incorrect coupling height!

Trailers that are not horizontal due to different coupling heights experience more wear at the coupling. The required turning movement is limited. Driving behaviour is influenced, which increases the risk of swaying. The trailer can become disconnected from your vehicle's ball hitch and will sway and tilt.



Driving with a worn / dirty ball coupler!

The trailer can become disconnected from your vehicle's ball hitch during the journey and will sway and tilt.



The ball head of the tow bar of your vehicle must be greased. This prevents premature wear and the appearance of grooves on the ball head and in the coupling housing (ball cap).

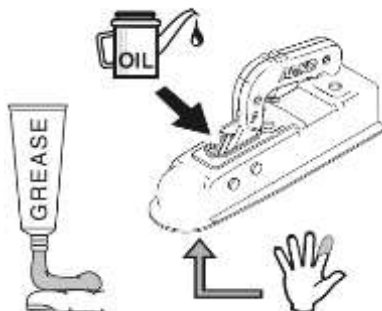

Loading and unloading

When loading a trailer, it is best to connect the trailer to the towing vehicle with the trailer's parking brake (braked trailer) engaged

The user should place the load in the centre of the trailer and over the axles as much as possible. This ensures an even distribution of the load, optimising the trailer's balance on the road and to achieve the best possible braking effect.

The centre of gravity of the load should be positioned over the axle(s) and as low as possible to optimise road holding. The load restraints used must comply with the EN 12915 standard.

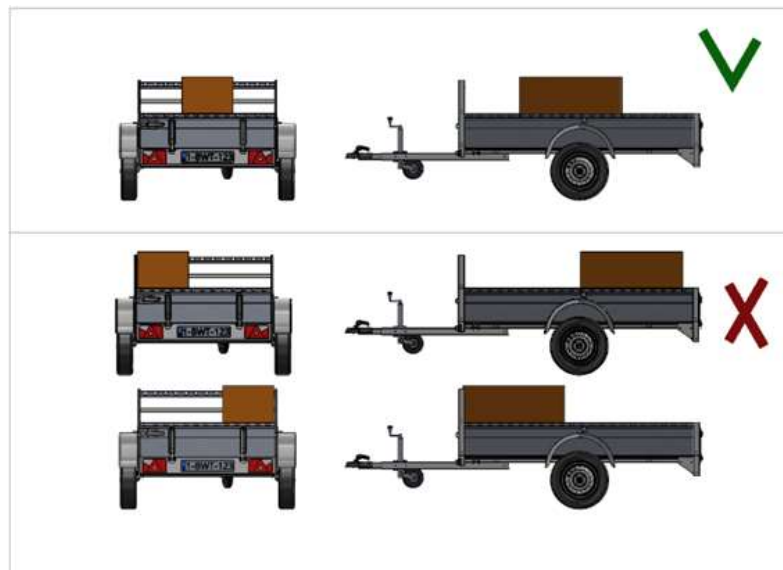

General points of attention :

- Make sure that no negative vertical load is created during loading of the trailer or that the maximum vertical load is not exceeded.
- To ensure good road holding, the centre of gravity of the load should be as close to the axles as possible and the load should be distributed between the left and right-hand halves of the trailer as evenly as possible. Concentrated loads should be avoided and large lighter loads should be distributed evenly.
- The load must be sufficiently secured to the intended points of attachment in accordance with national regulations.

Driving the trailer

When towing a trailer, the following steps must be taken to ensure that your vehicle / trailer is positioned on the road as safely as possible.

- Before setting off, make sure that the ball coupler is fully engaged, that the auxiliary coupling cable (unbraked trailer) or break away cable (braked trailers) is connected, that the jockey wheel (if present) is fully retracted and locked and that the lights are all working.
- Make sure that the load in combination with the trailer does not exceed the gross weight of the trailer and is firmly secured in the centre of the trailer.
- Observe the rules and regulations in force with regard to the maximum authorised mass (MAM) of the trailer (MAM = unladen weight + load).
- Check the tyre pressure of the trailer in accordance with the values given in this manual.
- Never exceed the locally applicable towing speeds.
- The national regulations of each country must be respected.
- Make sure that no negative vertical load is created during loading of the trailer or that the maximum vertical load is not exceeded.
- If optional brakes are fitted - ensure that the drawbar is as flat as possible to avoid twisting.
- Passengers must not sit in or on the trailer while the vehicle and trailer are in motion.
- Always adjust your driving style and speed, depending on the road you are driving on.



Excessive, not adjusted speed!

The trailer can start to sway, tilt and become disconnected from the towing vehicle. The load safety device may come loose and the load may fall down.

Poor road conditions / extreme weather conditions!

The trailer can sway, tilt and become disconnected from the towing vehicle in case of uneven roads with potholes or in case of severe weather, e.g. storms, slippery conditions due to snow, ice and hail.

Gusts / winds!

The trailer can sway, tilt or become disconnected from the towing vehicle during abrupt steering movements due to gusts/winds that can occur at bridges, tunnels, forest firebreaks, noise barriers or when overtaking trucks.

Too high load / structure!

A load / structure that is too high can snap when passing through tunnels, under bridges, in underpasses, etc. Before departure, check that the maximum permitted total height is not exceeded. Before entering a tunnel, underpass or bridge, pay attention to the road signs with the maximum permissible vehicle height.

Uncoupling

Open the coupling lever and lift the ball coupling of the tow bar ball from the towing vehicle. With higher ball pressures, lifting and lowering can be made easier by using a jockey wheel.

Make sure an unbraked trailer is on a level surface. If this is not the case, use wheel chocks.

Apply the parking brake (braked trailer) to prevent the uncoupled trailer from rolling away.

Remove the plug for the lighting.

Disconnect the auxiliary coupling (unbraked trailer) or break away cable (braked trailers) from the towing vehicle.



Risk of injury! The trailer can roll back!

When uncoupling or parking on a slope, always use a wheel lock.

If optional brakes are fitted - until the full braking force is applied, the trailer can roll back 25-30 cm!

When parking the trailer, ensure that there is sufficient distance.

Ball coupler braked trailers

Ball coupler components for type AK161 / AK 301 / AK 351

1. Handle
2. Coupling lever
3. Semi-ball shaped cap
4. Key hole
5. Wear indicator
6. Locking indicator



Coupling operation

Opening the ball coupler - for this purpose, pull the coupling lever up in the direction of the arrow.

The coupling mechanism has an "open" position, i.e. as long as the ball coupler is not placed on the ball, the coupling lever remains open.

Place the opened ball coupler on the tow ball of the towing vehicle.

Due to the ball pressure the ball coupling is automatically, audibly locked, in the starting position.

In the interests of safety press the handle down by hand as well.

Locking and securing takes place automatically.

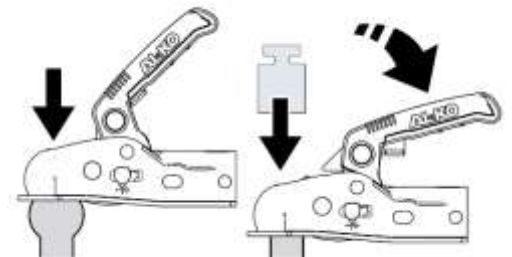
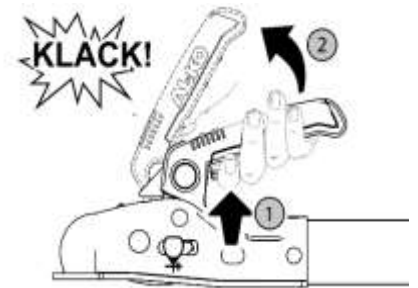

In any case, it must be checked that the ball coupler is correctly positioned on the ball.

Safety indicator

The coupling ball is correctly connected when at the front the green pal of the safety indicator is pushed out by the ball and becomes visible.

The coupling mechanism is correctly engaged when the coupling handle can no longer be pressed down by hand.

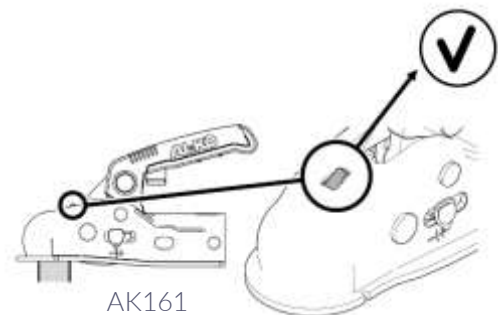
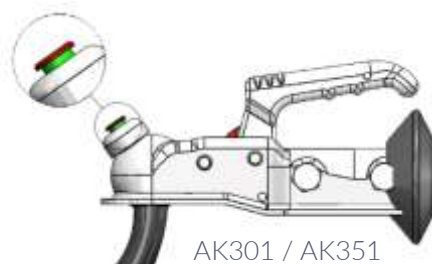



DANGER

Driving without a correctly coupled ball coupler!

The trailer can become disconnected from your vehicle's ball hitch during the journey and will sway and tilt.

Wear indicator

A wear indicator on the coupling lever indicates whether or not the wear limit of the tow ball of the towing vehicle or of the trailer coupling has been reached.

To check wear-and-tear, the trailer must be connected to the towing vehicle and driven for approximately 500m. The driving movement ensures that the coupling mechanism is optimally adjusted.

Marking is in the range (+):

- Ball coupler in new condition.
- The wear of the tow ball of the towing vehicle is within the permissible range.



AK301 / AK351



Marking is in the range (-):

- Ball coupler at the extreme wear limit \varnothing 49mm or smaller (no wear on tow ball).
- Tow ball is in new condition \varnothing 50 mm (ball coupler shows increased wear).
- Ball coupler and tow ball show wear-and-tear.

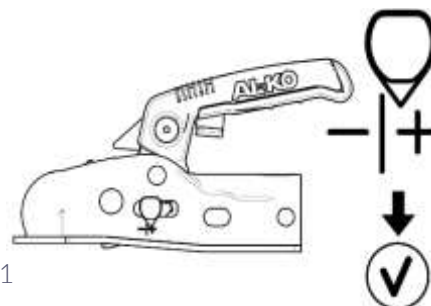

AK161



DANGER

Driving with ball coupler and/or tow ball showing a high level of wear-and-tear!

While driving, the ball coupler can slip off, causing the trailer to become detached from the towing vehicle. Have the ball coupler and tow ball checked immediately! Have the worn part replaced immediately.

Breakaway cable braked trailers

The breakaway cable activates an automatic braking process in case the trailer becomes disconnected while driving.



When redirecting the breakaway cable, ensure that the loop is sufficiently long. This prevents the breakaway cable from being pulled in tight bends.

Ways of attaching the breakaway cable

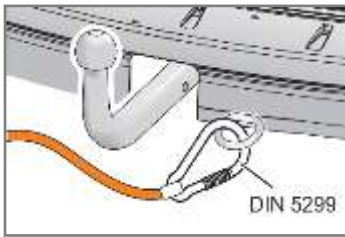

Version 1:

- Attach the carabiner with a catch to the eyelet of the towing vehicle.
- Check that the carabiner is completely closed.



Version 2:

- Insert the breakaway cable through the eye of the towing vehicle.
- Wrap the breaking cable around the ball neck.
- Attach the carabiner to the cable with a catch.
- Check that the carabiner is completely closed.



Version 3:

- Insert the breakaway cable through the eye of the towing vehicle.
- Attach the carabiner to the cable with a catch.
- Check that the carabiner is completely closed.



Version 4:

- Wrap the breakaway cable around the ball neck and the clamping bracket on the towing vehicle.
- Attach the carabiner to the cable with a catch.



Version 1 - only permitted with a carabiner according to DIN 5299 (min.70mm – firefighter's carabiner)



DANGER

Driving without or incorrectly installed breakaway cable!

The trailer would not be secured in case of uncoupling and or the breakaway cable may come off while driving.

The trailer brakes may not be activated, danger of accidents.



ADVICE

Install the breakaway cable in such a way that negotiating bends is possible without any problems.

The breakaway cable must not wrap itself around the nose wheel.

When installing the breakaway cable, observe the country-specific regulations.



The Netherlands and Switzerland are the only European countries that have rules for the installation of the breakaway cable. In both countries, the breakaway cable twisting around the ball neck is considered an offence. In the case of police checks, this can lead to high fines.

Overrun device with parking brake

Braked trailers have brakes with an overrun device that brakes the trailer fully automatically depending on the load. A parking brake serves to secure the trailer against rolling away and applies the brakes independently of the overrun device.

Non-braked trailers have neither an overrun device nor a hand brake.

Overrun device components for type 90S / 251S / 251G / AE 3500

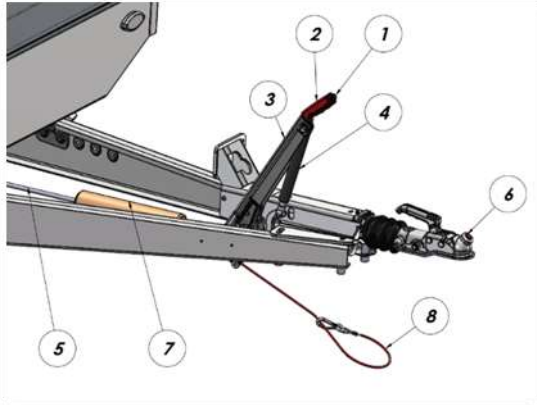

1. Lock button
2. Handle
3. Parking brake handle
4. Gas spring
5. Brake rod system
6. Ball couplers
7. Spring accumulator (depending on model)
8. Breakaway cable

Parking brake operation for lever with gas spring support

Apply

1. Pull the parking brake firmly.
2. The parking brake handle is positioned vertical.

Release

1. Press and hold the lock button.
2. Release the parking brake and return it to the starting position beyond the dead-center position.

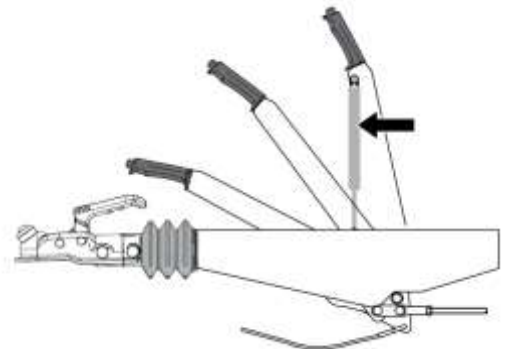

Overrun device types

AL-KO 90S



AL-KO 161S/251S



AL-KO 251G



AL-KO 2.8VB-1



AL-KO AE 3500



 **DANGER**



Danger of injury when parking the trailer!

Until the full braking force is applied, the trailer can roll back 25-30 cm! When parking the trailer, ensure that there is sufficient distance.

Releasing the parking brake when the trailer is not secured!

The trailer can start moving uncontrollably and can hit/injure people.

First attach your trailer to the vehicle or only release the parking brake if your trailer is secured with extra wheel chocks.

Driving with the parking brake applied!

The parking brake locks the wheels and the trailer will start to sway.

Before setting off, check that the parking brake is released.

Exceeding the maximum permissible drawbar load!

A break may occur with the overrun brake/ball coupler. The trailer may start to sway and tilt while driving.

Observe the maximum permitted drawbar load of the trailer.

Observe the maximum permitted drawbar load of your towing vehicle.

Never exceed the maximum permissible values of your towing vehicle and the ball coupler.

Wheels and tyres

Wheels and tyres are important safety components on the trailer. They directly increase the driving comfort and improve the driving behaviour of the trailer.

Visually inspect the wheels regularly and replace if:

- cracks can be seen in the rim or tyre.
- the rim shows deformation.
- the bolt holes are deformed.
- there is considerable rust formation between the tyre and the rim.
- wheel bolts are broken.



The wheel size shall be appropriate to the type of trailer and shall not be changed as such. The permitted wheel / tyre size can be found on the COC document of the trailer under point 35. Defective wheels must be replaced immediately! Do not take any safety risks!

As the tyres are subject to permanent wear while driving and to ageing, they must be checked regularly.

Regularly check:

- Tyre pressure in cold condition
- Tread depth of the tyre in the centre of the tread.
This must be at least 1.6 mm.



Weather conditions, including sunshine, cold weather, etc. will greatly influence the life of tyres. Tyres must not be older than 6 years after production date.

When replacing tires, take into account the load and speed index stated on the tyre.

The load index is given in a numerical code, corresponding with the maximum load that a tire can bear.

The speed index is indicated in a letter code corresponding the maximum speed of the tire.

Tyre	Max. Tyre pressure (bar)	Speed index	Max. speed (km/h)	Load index	Max. load (kg)
155/80R13	2.4	N	140	78	615
165R13C	4.6	N	140	96	710
185R14C	4.5	N	140	104	900
195/50B10	6.0	N	140	98	750
195/50R13C	6.5	N	140	104	900
185/60R12C	6.5	N	140	104	900

Conversion bar / psi / kPa:

- 1 psi = 0.0689 bar
- 1 bar = 14.504 psi
- 1 kPa = 0.01 bar



The maximum tyre pressure applies to both empty and fully loaded trailers.

WARNING

Wheel bolts come undone!

Wheels can come off while driving - danger of accidents!

Tighten the wheel bolts alternately after the first 50 km and after each wheel change.

Regularly check the tightness of the wheels with a torque wrench (tightening torque 100 Nm).

Worn tyre profile or incorrect tyre pressure!

Wheels can burst while driving - danger of accidents!

Longer braking distance - danger of swaying!

Check tyre pressure regularly.

Check the tread depth (< 1.6 mm = tyre replacement).

Imprudence in traffic!

When changing a wheel, you can obstruct the flow of traffic - danger of accidents!

You can get hit by passing vehicles!

Make the location on the road secure by placing a warning triangle. Use protective clothing.



CAUTION

Hot brakes (braked trailers)

You can burn yourself on hot brakes when changing wheels.



Let the brakes cool down before changing a wheel. Wear protective gloves!

ADVICE

Driving with incorrect tyre pressure

The tyres wear out excessively.

Before departure and at the latest after 14 days, check the tyre pressure in cold condition.

Hydraulic lift function

When using the tipping mechanism, observe the following instructions before starting the procedure:

- The person operating the tipper has read and understood the instructions for operating the tipper.
- No one should stand on or near the trailer while tipping, except the person with the relevant expertise to operate the tipper.
- The trailer must be stationary and correctly coupled to the towing vehicle. The use of supports and wheel wedges is recommended if stability cannot be guaranteed without these items.
- The ground under the trailer must be sufficiently stable to allow safe execution of the tipping movement. If this is not the case, measures must be taken to ensure the ground is stable. The tipping movement must not be carried out on a surface that is too steep.
- The tipper must be able to carry out the tilting movement safely and without hindrance. Be careful not to get trapped between the bucket and the frame or side, front and rear flaps during tipping.
- Do not use the tipper in potentially explosive places.
- Hoses, attachment points, oil and battery must be checked for soundness, completeness and usability before the tipping function is activated.
- Ensure adequate lighting at the workplace during activities.
- The lighting on the trailer is not (clearly) visible during tipping. Take measures to compensate for this, for example by placing a warning triangle or warning lights behind the vehicle when tipping on public roads.



If the trailer's tipping function is not used, the power supply must be interrupted to prevent unintended (re)activation.

The power supply can be interrupted on the control box by setting the switch to the "0" position using a red key.



Hydraulic lift function control

1. Turn the jockey wheel downwards.
2. Detach the load if it is still strapped in.
3. Open the tailgate of the bucket.

5. Turn the main power switch key clockwise to turn on the electrical installation.
6. To lift the bucket, press the white button until the desired height is reached.
7. To lower the bucket, press the black button until the bucket is back on the chassis.
8. Turn the key of the main power switch counter-clockwise to turn off the electrical installation.

5. Close the tailgate of the bucket.
9. Turn the jockey wheel up.

Floor support loading floor

Support the deep loading floor with the floor support during delays or during maintenance work on the trailer.

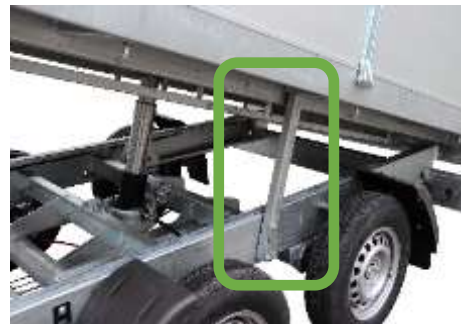

Hazard zones during tipping



DANGER



Danger of crushing between chassis and loading floor!

You can get trapped between the chassis and the loading floor if the floor support is not used correctly.



Standing under an unsecured trailer!

The trailer may start to move, slide off the lifting device and tilt - danger of crushing!

Secure the trailer against rolling away by means of wheel blocks - place them under intact wheels.



Before changing a wheel, check that the trailer is on a flat and firm surface. If necessary, use a firm underlay under the lifting mechanism.

Apply the parking brake if fitted.

Do not go under the trailer if it is not stable or if you are using an unsuitable/unsecure lifting device.

Keep other helpers away from a raised/unstable trailer.

Cleaning

The trailer can be cleaned with water. If you use a high-pressure cleaner, the following rules must be observed:

- Distance to surface min. 70 cm
- Water pressure max. 50 Bar
- Water temperature max. 80 °C



During cleaning, the electrical components must not come into contact with water.



Do not clean the following parts directly with a high-pressure cleaner:

- Coupling and parking brake (optional)
- Lighting, plugs and cables
- Marking stickers
- Tyres
- Hydraulic components (only for tippers)

Galvanised parts

The galvanised parts of the trailer (e.g. chassis, drawbar) must first oxidise to develop a corrosion-resistant effect. This may take several months. Only when the surface loses its zinc shine, is an anti-corrosion layer created.

A white rust can form on these parts. These are zinc oxides that form from moisture on galvanised parts. In order to avoid the formation of rust as much as possible, air must circulate sufficiently during storage so that no water film can form between the metal surfaces. Incidentally, the protective effect of the zinc layer is not reduced by the stains. White rust does not constitute damage and is, therefore, no reason to submit a claim.



Galvanised parts are not resistant to salts and acids (e.g. road salt, brine, fertilisers). Clean and dry the galvanised parts after contact with aggressive substances.

Aluminum parts

Aluminium parts profiles (e.g. side panels) have an anodised coating, which offers optimal protection against corrosion.

Storage / Parking

If the trailer is not used for an extended period of time, the following storage instructions apply to avoid possible problems when the trailer is reused:

- If possible, park the trailer in a shed or building, otherwise cover with a tarpaulin.
- Park at a location with adequate thief protection.
- Park on a flat surface.
- Remove any load from the trailer before storing it.
- Lock the wheels of the trailer or apply the parking brake if fitted.
- Ensure there is sufficient ventilation in the loading space.

End of life cycle

This trailer contains certain materials that can be harmful to the environment, such as tyres. These must be disposed of properly, according to local environmental regulations. The tyres must be disposed of at a waste point. The trailer as a whole must be taken to a local scrap yard.



Troubleshooting

<i>Defect</i>	<i>Cause</i>	<i>Solution</i>
COUPLING		
Ball coupler does not click into place after coupling	Ball cross-section greater than Ø 50 mm	Have tow ball replaced
	Insufficient pressure on ball	Push ball coupler down manually
	Inside of ball coupler dirty	Clean and lubricate ball coupler ; replace if necessary.
Trailer cannot be uncoupled		Set up and uncouple the trailer and the car in the same direction of travel.
	Tow ball oval-shaped	Lubricate or oil coupling mechanism
	Lock latch not pressed down	Press down lock latch
Too much play between ball hitch and ball coupler	Ball coupler worn	Replace ball coupler
	Swivel range exceeded	Have tow ball replaced.
TRAILER LOAD		
Trailer swaying	Tyre pressure is set too high	Reduce air pressure on all tyres. Observe the maximum air pressure values of the tyres.
	Excessive speed	Reduce your speed slowly
	Centre of gravity of the load is too far to the rear. Ball pressure is insufficient or negative	Correct the centre of gravity of the load to the front. Correct the load distribution to ensure sufficient drawbar load is available.
Trailer is flapping	Load is not secured	Secure the load properly
	Cables or hoses become loose	Have these secured in a specialized workplace
	Nose wheel is not sufficiently turned upwards, if at all	Turn the nose wheel upwards and have damaged parts replaced
	Parking brake is still applied	Release the parking brake
	Cover is not closed	Close the cover completely
	Concrete nets are not securely fastened	Check the fastenings of the concrete nets
	Side panels are not properly closed or secured.	Check the closures of the side panels
	Lubrication points are not sufficiently lubricated	Lubricate all lubrication points
A defective wheel bearing	Replace wheel bearing	
Trailer tends to move to the right or left	Load is not evenly distributed	Distribute load evenly
	Tyre pressure is uneven	Adjust air pressure so that all the tyres have the same air pressure
	Load is not sufficiently secured (non-slip) and is moving slowly	Align the load evenly and secure the load in a non-slip manner
	Brake of one wheel is incorrectly adjusted and brakes	Have it adjusted correctly in a specialized workplace

<i>Defect</i>	<i>Cause</i>	<i>Solution</i>
BRAKES		
Insufficient braking performance	Incorrect adjustment - excessive free travel	Calibrate
	Braking lining not run-in	Brake a few times
	Braking lining damaged - dirty	Have brake shoe set replaced
	Excessive friction losses at draw bar	Lubricate transmission devices, including brake cable
	Corrosion to the drawbar	
When reversing trailer is heavy or is blocked	Brake system is set too tight	Brake system readjustment
	Rückmatic-lever is stuck	Lubricate
Overheating of the brakes while driving forward	Incorrect setting	Recalibrate
	Braking system still (partly) activated	Release parking brake
		Check transmission devices (normal operation)
	Transmission lever is stuck	Check transmission lever of the overrun device (normal operation)
	Brake rod guide is bent	
	Wheel brake dirty	Clean
	Cable / brake cable kinked	Replace brake cable
	Tension springs weak or broken	Replace springs
Rusty brake drum	Replace brake drum is necessary together with brake shoes	
Trailer brakes with released accelerator pedal	Shock absorber defective	Have brake shoe set replaced
Trailer brakes when driving in reverse	Corrosion and/or lack of lubrication for the wheel brake	Clean and regrease the moving parts of the wheel brake
Restless driving behaviour, including sudden braking	Too much air in the transmission device	Calibrate
	Shock absorber defective	Replace shock absorber
Overrun device hits end stop audibly and noticeably	Shock absorber defective	Replace shock absorber
Overrun device overruns	Too much air in the transmission device	Calibrate
	Braking linings worn	Have brake shoe set replaced

Maintenance

Trailers must be inspected by a competent / qualified specialist for their safe working order as and when required, but at least once a year in normal use (max. 10,000 km per year). If necessary, the service interval must be adapted to your usage routine and operating conditions.

Service obligations

The following work is the responsibility of the user / owner :

- Compliance with the manufacturer's prescribed maintenance intervals and service work.
- Regular maintenance / cleaning of the trailer of contaminations / foreign objects.
- Regular presentation of the trailer for technical inspection if required.



Failure to follow the maintenance instructions may reduce or invalidate the manufacturer's product liability or warranty!
We recommend an inspection interval of 1 year.

Following maintenance work should be done periodically at regular intervals:

- Regular visual inspection / inspection of the trailer and components for damage, contamination and wear.
- Functional test of the trailer and of the individual components.
- Periodic lubrication work on grinding points and repair of individual parts.
- Adjusting / tightening of unscrewed screw / clamp connections.
- Repair of worn, defective, safety-relevant parts by qualified personnel in a specialist workshop.



As a user of the trailer, you may only carry out limited maintenance. Certain maintenance work may only be carried out by qualified personnel!

Safety parts

Safety-relevant components are included:

- Axles
- Brakes and overrun brake
- Couplings
- Wheels / tyres
- Screw connections of supporting parts e.g. drawbar, axle connection
- Load floor support (only for tipper trailers)
- Hydraulic components - manual or electrical (only for tipper trailers)
- Attachments e.g. gas springs, wheel shock absorbers
- Electric systems lighting e.g. lighting, battery



For safety reasons, all safety-relevant components must be regularly checked and maintained by qualified personnel.

Damaged and non-functioning parts of the trailer must be replaced by original spare parts from BW Trailers BV.

The accident prevention and environmental regulations must be observed during all maintenance work.

Maintenance intervals axles and bearing

Maintenance intervals braked axle with ball bearing

Type: AL-KO B 700-5 / B 1200-6 / B 1600-3 / B 1800-9

After 1.500 kms or 6 months (first inspection)

- Check the axial play of the wheel hub bearings and have them adjusted if necessary
- Check braking system and adjust if necessary

Every 10.000 kms or 12 months

(wheel brake 1636G/1637: every 5.000 kms or 12 months)

- Check the axial play of the wheel hub bearings and have them adjusted if necessary
- Check the quantity and condition of the grease and re-lubricate if necessary
- Check the wear of the lining of the wheel brakes every (inspection hole). If necessary, have them adjusted, or replaced when less than 2mm

Every 30.000 kms or 24 months

(wheel brake 1636G/1637: every 10.000 kms or 24 months)

- Maintenance of the braking system
 - Check whether the movable parts in the brake drum are still optimal.
 - Replace brake shoes and any defective springs.
- A new crown nut must always be used to secure the brake drum



If the trailer is used permanently in mountainous areas, the trailer brake is exposed to greater wear. For commercial trailers, there is a risk that adjustments may have to be made earlier.

Safety instructions for axles

- AL-KO axles may not be welded.
- The rim data must match the axle data (wheel connection, rim inset depth, wheel bolt data).
- The type designation must not be rendered illegible by paint or obscured by components



All necessary maintenance work may only be carried out by trained personnel in special workshops or service centres.

Bearing maintenance

The bearings used are maintenance-free. If the bearings are damaged, replace the entire brake drum. The bearings are integrated in the brake drum.



In the case of trailers coming into contact with water, the wheel hub bearings must be greased shortly after the trailer has driven through the water (with the exception of the waterproof hub).



Spare parts are safety parts!

If no original AL-KO spare parts are used, the warranty and product liability will be invalidated. This means that we as a manufacturer are no longer liable for possible defects and consequences. The possibility of consequential damage and even physical injury should not be underestimated on the public roads. This must be taken into account when purchasing spare parts!

Lubrication work

Use only the specified lubricants for lubricating and oiling the parts.

Type of lubricants

- Multifunctional grease according to DIN 51825
- Machine oil

Lubrication intervals

- For overrun brakes every every 10.000 – 12.000 km or every 12 months
- For ball couplings every 3 months depending on use



The lubrication intervals must be adjusted according to the intensity of use and the degree of contamination

Lubrication points for overrun device

type AL-KO 90S / 161S / 251S / 251G / 2.8VB

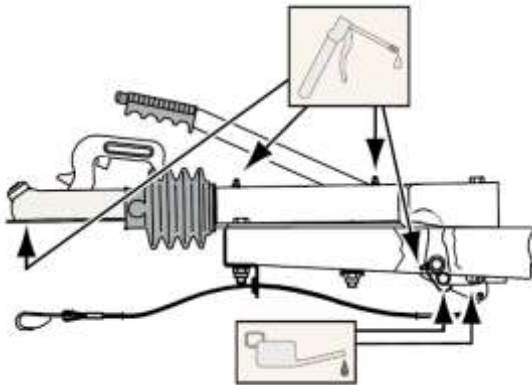

type AL-KO AE3500

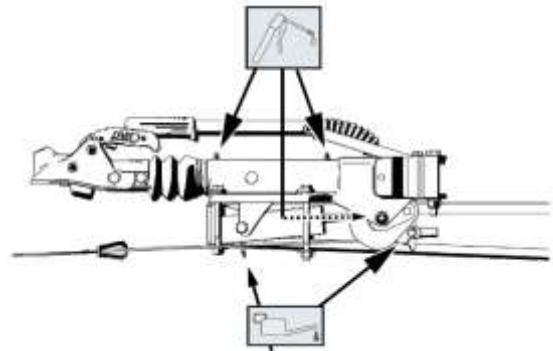

Lubrication points for ball couplings

type AL-KO AK161

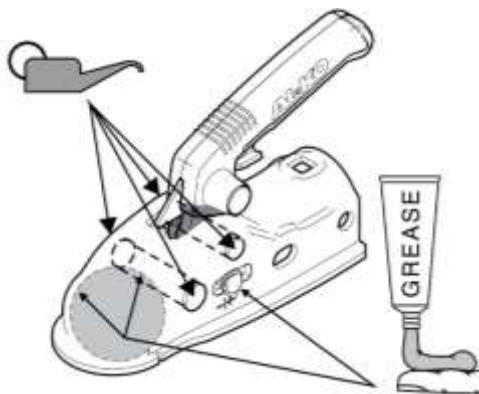

type AL-KO AK 301 / AK 351

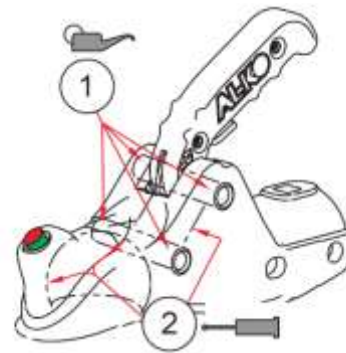

Before lubricating

- Remove the old grease / waste oil completely from the lubrication points.
- Remove any contaminants.
- Clean the lubrication points and the lubrication nipples with a clean dry cloth.



ADVICE

Contaminated grease nipples.

Contaminants can enter the bearing and lead to increased wear.
Clean the grease nipples before lubricating.

After lubricating

Wipe away any excess grease or oil that has run out with a cloth.
Check the parts are working properly.



WARNING

System failure due to faulty lubrication!

Some parts must not be lubricated / greased under any circumstances. The components may refuse to work - danger of accidents!

Find out which parts must not be lubricated, for example: clamp tubes on extendable support legs and jockey wheels, threads on wheel bolts, brake linings, etc.



CAUTION

Contact with lubricant

Lubricants can cause skin reactions.

Use only approved lubricants.

Use appropriate protective equipment.

Wash your hands thoroughly after the lubrication has been carried out.



Service intervals and history

Observe the necessary maintenance and care instructions for the intended use. Have an inspection performed recorded and stamped.

<i>First service</i>	<i>1.000 km service</i>	<i>5.000 km service</i>
Date	Date	Date
Stamp BW Trailers - dealer	Stamp BW Trailers - dealer	Stamp BW Trailers - dealer
Signature	Signature	Signature
Inspection on delivery	max. 6 months after purchase	max. 1 year after last service

<i>10.000 km service</i>	<i>15.000 km service</i>	<i>20.000 km service</i>
Date	Date	Date
Stamp BW Trailers - dealer	Stamp BW Trailers - dealer	Stamp BW Trailers - dealer
Signature	Signature	Signature
max. 1 year after last service	max. 1 year after last service	max. 1 year after last service

<i>25.000 km service</i>	<i>30.000 km service</i>	<i>35.000 km service</i>
Date	Date	Date
Stamp BW Trailers - dealer	Stamp BW Trailers - dealer	Stamp BW Trailers - dealer
Signature	Signature	Signature
max. 1 year after last service	max. 1 year after last service	max. 1 year after last service

<i>40.000 km service</i>
Date
Stamp BW Trailers - dealer
Signature
max. 1 year after last service

<i>45.000 km service</i>
Date
Stamp BW Trailers - dealer
Signature
max. 1 year after last service

<i>50.000 km service</i>
Date
Stamp BW Trailers - dealer
Signature
max. 1 year after last service

<i>55.000 km service</i>
Date
Stamp BW Trailers - dealer
Signature
max. 1 year after last service

<i>60.000 km service</i>
Date
Stamp BW Trailers - dealer
Signature
max. 1 year after last service

<i>65.000 km service</i>
Date
Stamp BW Trailers - dealer
Signature
max. 1 year after last service

<i>70.000 km service</i>
Date
Stamp BW Trailers - dealer
Signature
max. 1 year after last service

<i>75.000 km service</i>
Date
Stamp BW Trailers - dealer
Signature
max. 1 year after last service

<i>80.000 km service</i>
Date
Stamp BW Trailers - dealer
Signature
max. 1 year after last service

Warranty and liability

All our trailers come standard with a 24-month warranty.

Warranty conditions

- The warranty only applies to defects that occur during normal use of the trailer and that are caused by inferior construction or materials, or by poor workmanship on the part of the manufacturer.
- Defects or imperfections in the goods delivered must be reported in writing to a recognised BW Trailers dealer as soon as possible, but no later than eight days after they have been discovered or when they could have been discovered.
- The report must also contain as detailed a description as possible of the defect, so that the recognised BW Trailers dealer and the manufacturer are able to respond adequately.
- If a defect is subsequently reported, the owner / user shall no longer be entitled to repair, replacement or compensation, unless a longer period is involved due to the nature of the case or the circumstances of the case.
- The guarantee consists of free replacement or repair of the defective product or parts thereof by the manufacturer or an authorised BW Trailers dealer.
- The warranty conditions of the respective supplier apply to installed third-party components. The warranty period may differ from that stated above.

The warranty claim lapses, among others, if

- the defect is the result of normal wear-and-tear, improper or incorrect use, use of tools other than those prescribed, or injudicious or incorrect maintenance.
- the defect occurs after modifications or repair by or on behalf of the buyer / user himself or by third parties and if it concerns a defect in the jockey wheel of the trailer.
- the condition of the trailer at takeover (by means of a handover check by the dealer) cannot be demonstrated.
- the service intervals (service after x months) are not demonstrable.

Liability

The manufacturer is not liable for unsafe situations, accidents and damage resulting from ignoring warnings or regulations such as:

:

- Improper or incorrect use or maintenance.
- Use for purposes or under conditions other than those specified in this documentation.
- The use of parts other than those prescribed.
- Repairs without the manufacturer's permission.
- Changes to the trailer, such as:
 - changes in the steering mechanism.
 - Welding, machining, etc.
 - Extensions on the trailer or steering system.
- If the customer has not met all the obligations towards the manufacturer (financially or otherwise).